

# Operator's Manual



**TANKER  
MAGNU  
20,000  
25,000  
30,000**



Congratulations!

You have just acquired a product that is the result of more than four decades of experience in grain transport, with proven success.

The 20,000, 25,000, and 30,000 Tankers meet your grain transfer and transport needs with high performance, efficiency, and ease of operation.

In order to obtain increased productivity and profitability, it's necessary for your harvesting equipment to work continuously. With this concept, the Tanker Magnu 20,000, 25,000 and 30,000 line was developed, in detachable carbon steel and stainless steel versions.

All equipment developed by Jan is exhaustively field-tested, in order to meet your requirements. Therefore, this Manual is another effort on our part to ensure your satisfaction with the product, allowing you to enjoy, in a practical and efficient way all the benefits that the Tanker offers.

In addition, this manual provides instructions for the correct preventive maintenance and conservation of the equipment, as well as instructions on how to proceed when Technical Assistance is required. Information is also provided about the Multi-Purpose discharge tube, an accessory made available to facilitate the handling and transfer of fertilizers, seeds, and granular materials.

Before operating the Tanker for the first time, carefully read all safety recommendations.

Our efforts do not stop there, as we have a Technical Assistance Department always ready to assist you: see chapter 9.

Contact us whenever necessary.

IMPLEMENTOS AGRÍCOLAS JAN S/A



<b>1 - Introduction</b> .....	<b>3</b>
<b>2 - Safety and Environment</b> .....	<b>7</b>
2.1 - Warning Symbols used in this manual.....	7
2.2 - Tanker Safety Decals .....	8
2.3 - Safety features on the implement .....	10
2.4 - Recommended Personal Protective Equipment (PPE) .....	11
2.5 - General safety and implement preservation .....	11
2.6 - Operating Safety .....	13
2.7 - Implement transport and movement .....	19
2.8 - Safety during maintenance .....	24
2.9 - Definition of responsibilities .....	26
2.10 - Emergency procedures .....	28
<b>3 - Get to know your Tanker</b> .....	<b>29</b>
3.1 - Intended application of the Tanker according to the design.....	29
3.2 - Left Hand Side / Right Hand Side Convention .....	29
3.3 - Tanker identification (serial number) .....	30
3.4 - Available versions .....	31
3.5 - Identification of components.....	32
3.6 - Technical Specifications .....	35
3.7 - Dimensions .....	36
3.8 - Hydraulic diagram.....	38
3.9 - Electrical diagram .....	39
3.10 - Optional accessories and configurations .....	40
3.11 - Loose items supplied with the Tanker.....	43
3.12 - Estimated service life and decommissioning .....	44
<b>4 - Assembly of the Tanker</b> .....	<b>45</b>
4.1 - Hitch assembly.....	45
4.2 - Rear axle assembly.....	46
4.3 - Hub and wheel assembly.....	46
4.4 - Rear support stand assembly .....	48
4.5 - Mounting the unloading pipe.....	48
4.6 - Discharge tube hydraulic cylinder assembly .....	49
4.7 - Driveshaft installation .....	49
<b>5 - Coupling the Tanker to the tractor and preparation</b> .....	<b>50</b>
5.1 - Tanker hitching to the drawbar .....	50
5.2 - Driveshaft assembly, adjustments and working angle .....	52
5.3 - Hydraulic hose connection .....	53
5.4 - Electrical connection.....	54

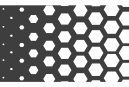

<b>6 - Tanker operation .....</b>	<b>56</b>
6.1 - Using the power take-off.....	56
6.2 - Tanker loading.....	57
6.3 - Tanker unloading: methods and procedures .....	58
6.4 - Use of the Easy Tarp system (optional) .....	62
6.5 - Use of the firefighting kit (optional).....	64
6.6 - Using the hydraulic brake (optional) .....	66
6.7 - Electromagnetic clutch kit (optional).....	67
6.8 - Agrobartt kit (optional).....	68
<b>7 - Maintenance instructions .....</b>	<b>69</b>
7.1 - Periodical maintenance chart.....	69
7.2 - Grease lubrication (daily) .....	69
7.3 - Lubrication of the transmission and rotation selection gearboxes .....	71
7.4 - Tire inflation .....	73
7.5 - Electromagnetic clutch adjustment (If equipped) .....	73
7.6 - Toe-In adjustment.....	75
7.7 - Wheel hub maintenance.....	76
7.8 - Wheel removal and installation.....	78
7.9 - Tanker cleaning and maintenance .....	79
7.10 - Suggested spare parts for stock.....	82
<b>8 - Troubleshooting and possible solutions .....</b>	<b>83</b>
<b>9 - Technical Assistance .....</b>	<b>84</b>
9.1 - Spare parts.....	84
9.2 - Jan Warranty Terms.....	85

**NOTE:**

- *Due to its policy of continuous product improvement, Jan reserves the right to make changes and enhancements without incurring any obligation to previously manufactured products. Therefore, the content of this manual is updated until the date it was printed, and may suffer changes without prior notice.*
- *The main objective of this manual is to provide instructions that cover the whole implement/machine with its attachments and variations. Therefore, it assumes no responsibility regarding the configuration of the implement just acquired; that is, some items described in this manual may not be present on your implement/machine.*
- *Some illustrations may show details slightly different from those found on your implement/machine, as they were obtained from prototype machines, without compromising the understanding of the instructions.*
- *Some pictures shown in this Manual were obtained by removing the guards and shields from the implement/machine in order to make identification easier. However, do not operate your Tanker without such protections.*
- *Work while respecting nature: do not dispose of waste, oils, filters, batteries, fuels and other contaminants in the environment. These practices harm your health, your family's health and even future generations. Send used products for proper recycling. The environment will thank you.*



Although we know that safety is, above all, a matter of awareness and common sense, this manual presents a series of precautions to be taken when using the Tanker Magnu.

Remember: every machine has capacities and limitations in use. For your safety, do not abuse them.

Please note that it is not possible to list here all risk situations involved in the assembly, operation and maintenance of the equipment and, as previously stated, common sense must be used.



### **NOTE:**

*Apart from the safety recommendations contained in this manual, review the recommendations contained in your tractor's Manual.*

## **2.1 - Warning Symbols used in this manual.**



### **NOTE:**

*This symbol here with the word "Note" indicate special interest points to maintenance or operation instructions. Failure to follow these recommendations may result in loss of performance, reduced useful life time and/or minor damage to the machine and indirect risks to your safety, in addition to the loss of the factory warranty.*



### **IMPORTANT:**

*The symbol beside and the word "IMPORTANT" are used to highlight special instructions and/or procedures that, if not observed, may result in early wear to the machine and risk of minor to moderate bodily injury, in addition to the loss of the factory warranty.*



### **ATTENTION!**

*The symbol beside and the word "ATTENTION" refer to instructions that, if not observed, represent a risk of accidents with serious bodily injuries and even death, in addition to serious damage or total loss to the equipment, in addition to the loss of the factory warranty.*





### 2.2 - Tanker Safety Decals

The Tanker has decals containing the major safety precautions related to the use of the equipment.

Always keep the decals in good condition. In case of damage or repainting of the Tanker, these can be obtained as replacement parts: simply request them using the code located in the lower right corner of the decals.



Code: 74141077 - Reflective strip for improved visibility.



Code: 74121041 - It is not recommended to operate the machine disconnected from the tractor drawbar.



Code: 74094004 - Retighten the bolts periodically.



Code: 74031122 - Do not approach the driveshaft with the machine in operation.

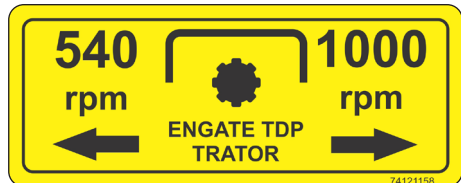

Code: 74121158 - Tractor PTO speed selection.



Code: 74074076 - Relieve hydraulic system pressure before performing any maintenance.



Code: 74074074 - Change the oil after the first thirty hours of work.



Code: 74121155 - Do not open the inspection cover with the machine in operation.



Code: 74121081 - Do not open the discharge tube when working near electrical power lines.

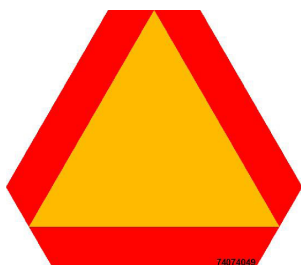

Code: 74074049 - Slow vehicle indicator.



Code: 74011012 - Grease daily.

### 2.3 - Safety features on the implement

The machine is equipped with several safety features, such as guards and decals (see item 2.2). Their proper use is essential for the safe operation of the Tanker.



**NOTE:**

*The images identify the guards in the operating position. Refer to items 2.7 and 6.3 regarding use in the Transport and Operating positions.*

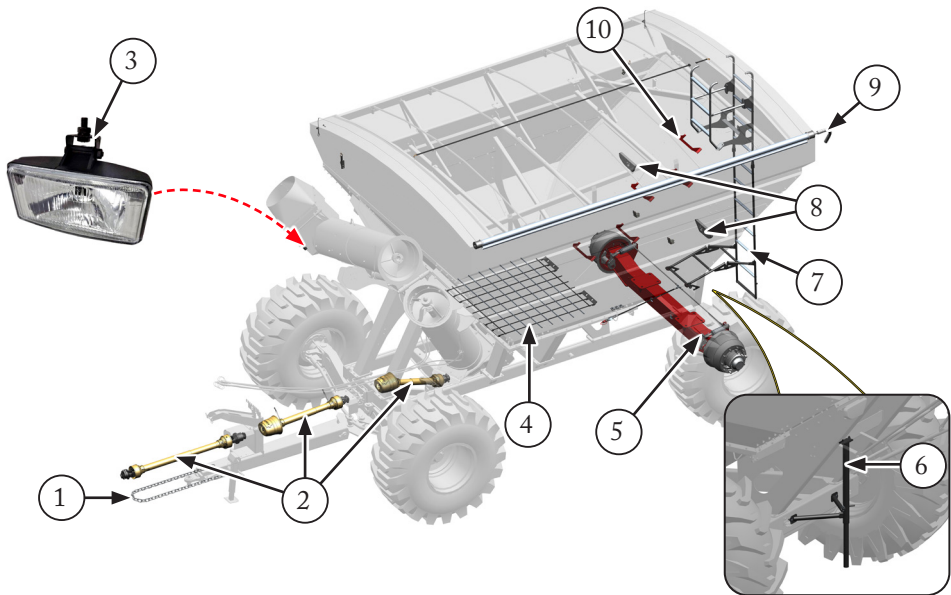

1. Safety chain: prevents accidental uncoupling of the Tanker from the tractor drawbar.
2. Driveshaft guards.
3. Discharge tube light.
4. Grate at the bottom of the Tanker hopper: prevents people and objects from falling into the auger intake.
5. Axle with hydraulic brake (optional).
6. Support stand: present only on the Tanker Magnu 20,000 model with one axle. It is located at the rear of the machine.
7. Rear ladder (internal and external): ensures safe access to the inside of the hopper.
8. Lighting system: the machine has lamps at the rear, one at each end of the hopper, to ensure proper signaling and lighting.

9. Easy Tarp System.
10. Access steps inside the hopper.

## 2.4 - Recommended Personal Protective Equipment (PPE)

All personnel involved in operation and/or maintenance must use the PPE recommended alongside:



**NOTE:**

*Additional personal protective equipment may be required or necessary depending on the specific application of the equipment.*

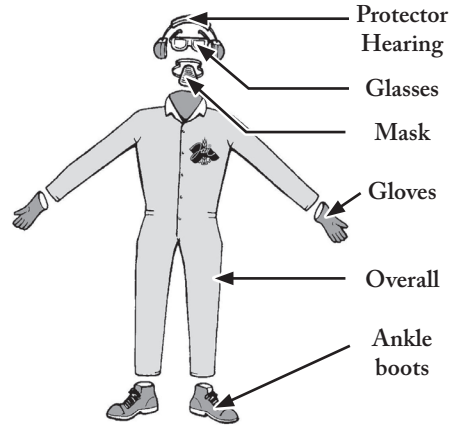

## 2.5 - General safety and implement preservation

Jan values the safety of those who use its products.

This manual provides essential guidelines that must be read and carefully understood. It is the responsibility of the equipment owner to be familiar with the operating procedures and the risks associated with its use.



*Read this manual carefully.*

*Failure to read this manual may result in serious accidents.*



*This implement has moving parts. Approaching or interfering with them may cause serious injuries, including amputation of limbs or death.*

- In addition to the safety guidelines presented in this document, also follow the instructions in your tractor manual.
- Check whether the tractor has adequate capacity to operate the Tanker; refer to the requirements in Technical Specifications, item 3.6.



- Never use the equipment if you notice any sign of structural, hydraulic, or transmission failure.
- In case of any doubt or suspicion, immediately stop the operation and inform the responsible person or contact Jan After-Sales Service: see Chapter 9.
- Personnel in training may only operate or assist in the use of the implement when properly supervised and instructed by qualified and experienced professionals.
- This manual must remain accessible and be known by all personnel involved in the operation.
- Use the PPE indicated in item 2.4.
- Avoid loose clothing and keep long hair tied back.
- Remove accessories such as watches, earrings, rings, chains, and similar items when working with the implement.
- Do not operate the implement if you are tired, under stress, or under the influence of alcohol, drugs, or certain medications.
- Do not smoke while operating or remaining near the implement.
- Turn off the tractor engine before performing any adjustment, maintenance, or other intervention on the Tanker.
- Make sure you are fully familiar with the equipment's operating and maintenance procedures. Before first use, present this manual and instruct the operators.
- Never allow unqualified persons to operate the Tanker or the tractor.
- Keep children and bystanders away during operation, maneuvering, or coupling of the implement.
- Do not allow people to be on, around, or inside the Tanker. This is only permitted with the equipment stopped, the engine turned off, and all measures taken to prevent falls and accidents.
- Always keep the implement in good working condition.
- Before starting movement, ensure there are no people, animals, objects, or obstacles in the path.
- Follow all instructions contained on the safety decals affixed to the implement.
- Perform proper cleaning of the implement.

## 2.6 - Operating Safety



### **IMPORTANT:**

*Prevent obstacles and risk of accidents: always uncouple the Tanker on a flat and level surface, blocking the wheels with suitable chocks to ensure complete immobilization.*

### **A) General precautions**

- Only load and unload the Tanker when it is hitched to the tractor.
- Operate the implement only with all protective components properly installed.
- Do not transport people during operation or movement.
- When making sharp turns, disengage the power take-off (PTO) and ensure that the tractor rear tires do not interfere with the Tanker hitch.
- When operating the implement, keep the jack (1) and support stand (2) clear of the ground.

*NOTE: 20,000 model with 1 axle only\**

- Only allow people involved in the operation to approach the equipment.
- Ensure that the wheel fastening nuts are always properly tightened.
- When working, especially on sloped terrain, exercise extra caution to maintain stability and control of the tractor and implement, using appropriate speeds for each situation.

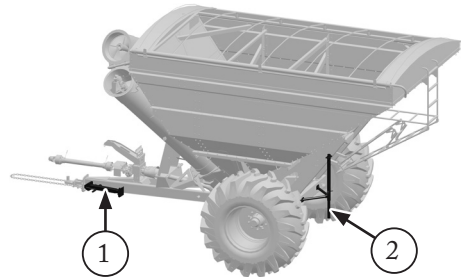

## B) Precautions when coupling and uncoupling the Tanker

- Ensure that the tractor drawbar is properly rated for the size and weight of the loaded Tanker: a drawbar that is too thin or too long will not support the implement load transmitted through the hitch.
- Use a suitable hitch pin (1) and always install a locking device (2).
- Perform tractor maneuvers at low speed and do not allow people to approach the implement or remain between the tractor and the equipment.
- Always disengage the Tanker on flat and level ground. Besides facilitating the procedure, it also makes the engagement safer and easier.
- Before uncoupling, make sure the Tanker will remain stationary. When in doubt, use appropriate wedges to chock the wheels.
- Use the jack (3) correctly, always installing the locking pin (4) and a safety cotter pin in both positions: rest and transport.
- When hitching the Tanker to the tractor, always connect the safety chain (5) to a structural point, such as the drawbar support.
- Do not move the tractor with the jack lowered (storage position).

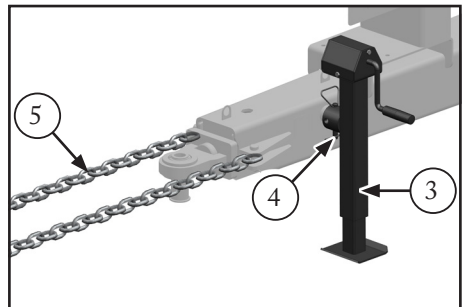
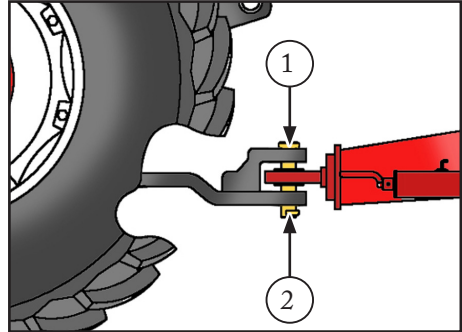

### C) Hopper and ladder:

To open and close the ladder:

- a) Fold the retractable ladder assembly (1).
  - b) Engage the hooks (2) onto the side pins of the ladder. Always hold on with both hands and use the appropriate PPE.
- Always hold on with both hands on the ladder (3) and use the appropriate PPE.
  - The interior of the hopper is smooth and may cause slipping and injuries. To avoid this, use the internal ladder (4) and the steps (5) provided for this purpose.
  - Never enter the tank with the unloading pipe in operation.

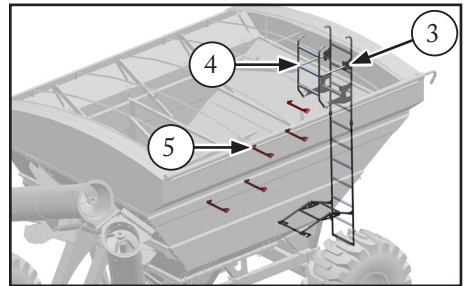
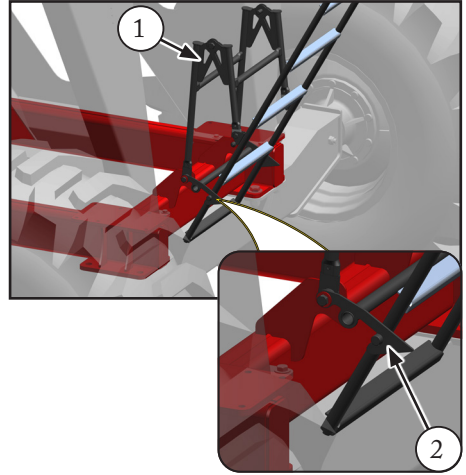

### D) Use of the support stand



#### **ATTENTION!**

***Tanker 20,000 with single axle!***  
***When the Tanker is unhitched from the tractor (supported only by the hitch support stand) and/or positioned on soft ground, use the support stand (1).***

***If necessary, place a board under the foot of the support stand so that it does not sink into the ground.***

***Lock the support stand (1) correctly by installing the pin (1a). Incorrect use - or non-use - of the support stand (1) may cause the front of the Tanker to tip up.***

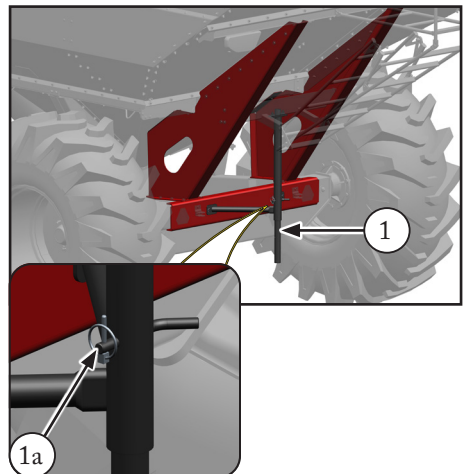

### E) Power Take-Off (PTO) and rotating components

- When making sharp turns, disengage the power take-off and ensure that the tractor rear tires do not interfere with the Tanker hitch.
- Never approach the driveshaft or moving components.
- Do not wear loose hair and/or loose clothing when operating machinery.
- Only connect the driveshaft to the PTO shaft with the engine shut off.
- When connecting the driveshaft for the first time, check that its length is appropriate: see item 5.2.
- Don't start or shut off the engine with the power take-off (PTO) engaged.
- Never exceed a 30° angle of the driveshaft during operation.

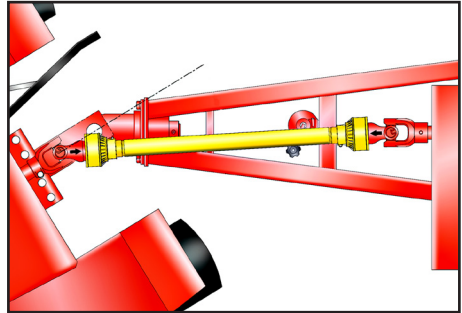

### F) Discharge tube

- When opening the tube, ensure there is sufficient clearance, i.e., no risk of interference or damage to the tube.
- When opening the tube, do not allow people to approach, especially at the joint point - image beside: there is a risk of amputation of the body parts hit.
- Always close (fold) the discharge tube for Tanker transport, opening it only to perform grain unloading.

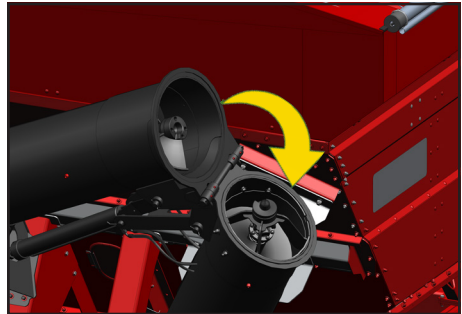

This care is important to:

- Avoid the risk of interference of the open tube with obstacles such as: trees, buildings and transmission lines.
- Avoid cracks between the unloading tube and the Tanker.



### ATTENTION!

#### *Tipping hazard!*

*When unloading the Tanker, make sure that it is level.*

*If the ground has a slope, the unloading tube should be facing the side of the incline, i.e. the higher side.*

*However, we recommend that unloading be performed only in locations with less than a 15° slope.*



### G) Tanker-to-tractor relationship:

- Read the safety rules of your tractor's Manual, especially those regarding care over it.
- Especially when operating on sloped terrain, take all precautions to maintain tractor stability and directional control, such as:
  - Only pull the Tanker loaded with a properly sized tractor. A very light tractor or one with insufficient power can lose control.
  - Use correct ballast for the tractor's front and rear axles.
  - Always lock the brake pedals together using the coupling lock (1).
  - Maintain a speed suitable for the conditions of each situation. When sloping down, always engage the gear that would be used for sloping up.

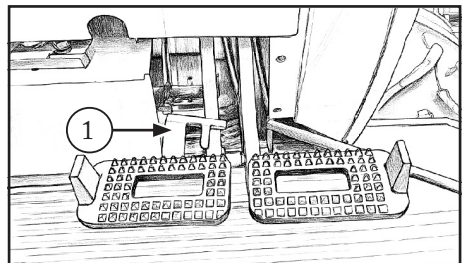
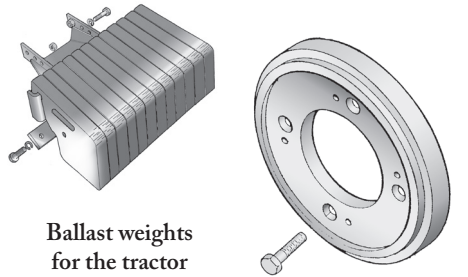

Image for reference only



- Do not drive the tractor sideways in relation to the slopes, but in a perpendicular direction, that is, move the tractor up or down but not sideways.
- When making sharp turns, disengage the PTO and make sure that the rear tires do not interfere with the Tanker hitch.

### H) Safety around power lines

- When traveling or operating near power lines, always observe the clearance between the equipment and the power line cables. Also check the lateral distance from poles, towers, and guy wires.
- High-voltage lines require additional clearance to ensure safe operation.
- If there is any doubt regarding safe distances, consult the local power utility or the appropriate authorities.
- Before passing under electrical cables, check for any raised or extended components on the equipment.
- Retract or lower any raised parts before continuing movement.
- Never park the equipment under or near power lines.
- When encountering a downed cable, do not approach and prevent others from doing so.
- Immediately notify the power utility company responsible for the electrical network.

### Guidelines

In case of contact with energized cables, strictly follow the instructions below:

- Stop the equipment immediately and shut off the engine.
- Assess whether it is possible to leave the equipment without touching the wires.
- If it is not safe, remain on the equipment and request assistance.
- Do not touch the downed cable or any metal component in contact with the power line.





- Do not allow people to approach.
- Only power company technicians or firefighters are authorized to perform rescue or equipment release procedures.
- If you have a phone, contact third parties, the power utility, and/or the fire department.
- If you do not have a phone, remain at the operator's station until help arrives.

**In case of fire in the tractor or any other situation that makes it impossible to remain at the operator's station.**

To exit the equipment safely:



### ***ATTENTION!***

***Never touch the ground and the equipment at the same time. This simultaneous contact causes an electric shock through the body that is usually fatal!***

- The only safe way to leave the equipment is by jumping away:
  - Jump with your feet together.
  - Jump away from the point of contact between the equipment and the electrical line.
  - After jumping, move away without separating your feet (moving in "bunny hops") until reaching a safe distance.
- Allow only power company crews and/or firefighters to approach.

## **2.7 - Implement transport and movement**

### **A) Travel on public roads**



### ***ATTENTION!***

***The movement of the implement coupled to the tractor must not be carried out on public roads and highways. This practice must be limited to within properties and rural areas.***

- Consult the traffic authority regarding the regulations in force in your region about the possible use of the Tanker with a tractor on certain road sections.
- Request guidance, authorization, and procedures in writing.

- In locations and situations where movement is authorized, follow precautions such as:
- Only properly licensed operators must drive the tractor, in compliance with the license category requirements.
- On flat roads, do not exceed the speed of:
  - 20 km/h with the hopper loaded.
  - 30 km/h with the hopper empty.
- On uneven roads, reduce speed sufficiently to ensure safety.
- Be informed about mandatory safety devices, such as the SMV decal (1), lights and lamps, turn indicators (flashers), among others.
- The SMV decal is installed at the rear of the Tanker. The tractor must also have its own SMV emblem.
- Keep the brake pedals (2) locked together throughout the entire route, ensuring uniform braking on both wheels. Before entering the road, check that the brakes, headlights, taillights and turn signals are working properly.
- Always drive the tractor on the appropriate side of the road.
- Activate the hazard lights.
- Even during the day, keep the headlights on.

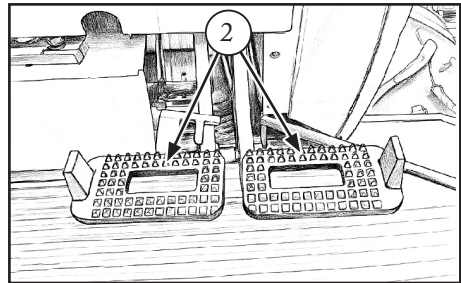
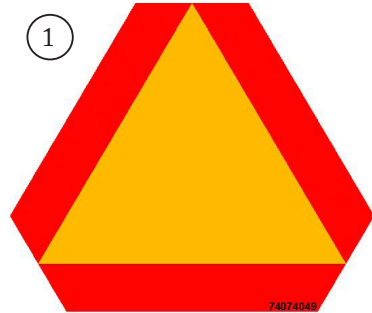
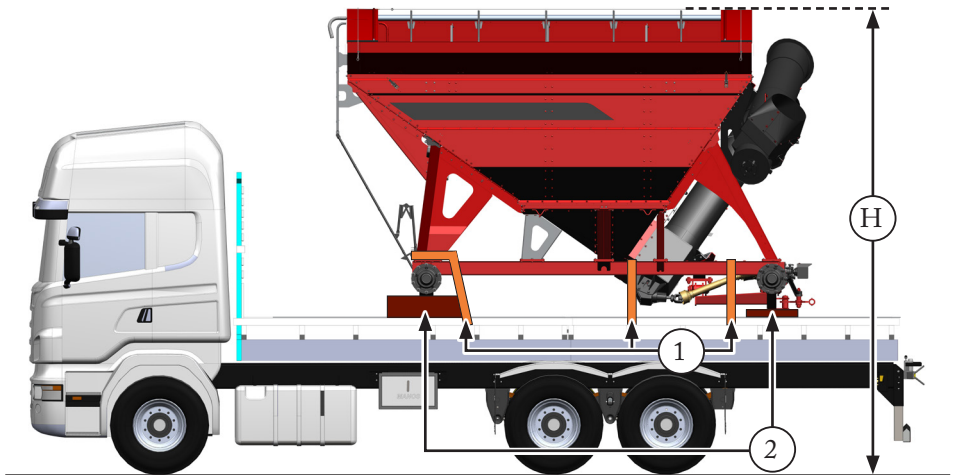

Image for reference only

### B) Transport by truck



Model 20,000 with one axle



Models 20,000, 25,000 and 30,000 with two axles

- For long-distance travel or when operating on public roads, transporting the Tanker by truck is recommended, as it is the safest method. Even so, this procedure must comply with the requirements established by current traffic legislation.
- Loading the implement onto the truck must be performed by lifting, using the 4 lifting lugs located inside the hopper.



### **IMPORTANT:**

*Forklifts or cranes must not be used for moving the Tanker.*

- Transport must be carried out exclusively by professionals qualified for this type of operation and using a truck properly sized for the load.
- Each strap or cable (1) must have a load capacity at least twice the total weight of the Tanker and must be equipped with a ratchet to ensure full stability during transport.
- For Tanker models with two axles, wooden chocks (2) must be used at the ends of the front and rear axles.
- Check the permitted height limit (H), measured at the highest point of the Tanker.
- When passing under overpasses, observe the indicated clearance height! Exercise extra caution when passing near trees, power lines, etc.
- Keep the hydraulic hoses properly coiled and secured to prevent them from coming loose and posing risks to other vehicles or people on the road.
- Ensure that no component or part of the machine remains loose on the truck bed.
- For the Tanker Magnu 20,000 model with one axle, the front discharge tube must be retracted, the wheel assembly removed, the jack and ladder must be in the transport position and the rear driveshaft secured on the support. On models with two axles, in addition to the other items mentioned for the 20,000 model with one axle, the rear axle, front hubs and hitch must also be removed.
- In the case of a flatbed truck, removal of the wheel assembly is not required.
- The hopper must be empty.
- The machine must be positioned and fully secured on the truck platform, with no lateral overhang.
- Support the Tanker structure on the truck bed floor.

- The machine must be secured using straps (1) or steel cables (on both sides of the machine), anchored at structural points: hitch and axle ends, as indicated:

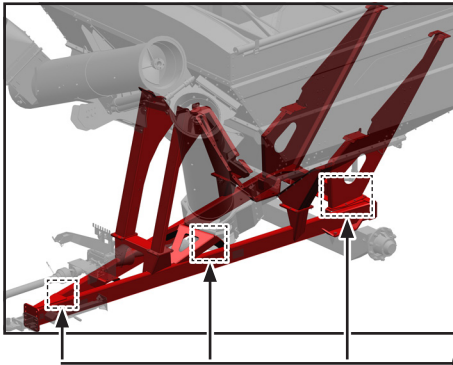

Model 20,000 with  
one axle

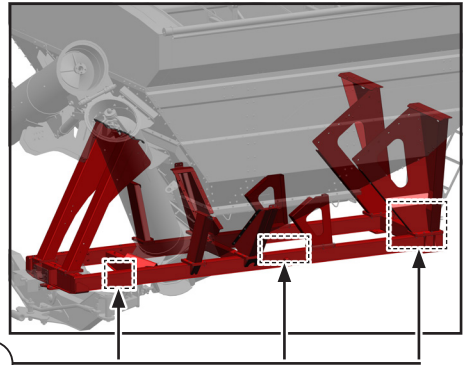

Models 20,000, 25,000  
and 30,000 with two  
axles



**IMPORTANT:**

*The implement must be secured exclusively at structural points and never on moving components or others that do not have a structural function, as this may cause serious damage.*



## 2.8 - Safety during maintenance

- If the tractor is coupled to the Tanker, always shut off the engine before performing any maintenance or adjustment. Engage a low gear, apply the parking brake, and remove the ignition key.
- Position the equipment on a flat, level, and firm surface, ensuring proper support to carry out the work.
- Clean both the operating area and the implement beforehand.
- The presence of oils, grease, or other residues may cause slips and falls.
- Take precautions when handling oils and grease, as these products contain carcinogenic chemical components. If contact with eyes or ingestion occurs, seek medical attention immediately.
- When removing one or more wheels, never leave the implement supported only by the jack; use strong and stable blocks under the structure or axle.
- Never remain under parts that are supported only by a jack or lifting devices. Safety in these cases can only be ensured by using properly rated jack stands, stable and supported on solid surfaces.

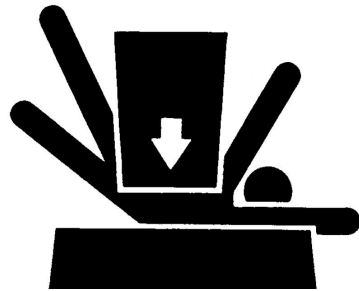

### Take proper fire prevention precautions, such as:

- Keep a fire extinguisher always available in the work area.
- Keep the implement and the environment clean, free of oil, grease, straw, or any other flammable material.
- Do not smoke while performing the activities.
- If lighting is insufficient, never use an open flame to illuminate the area, as there is a high risk of fire.
- If access to elevated parts of the implement is required, use appropriate ladders or scaffolding, with proper strength, well leveled and firmly supported.
- Never loosen hydraulic connections in pressurized systems: the oil jet may penetrate the skin and cause injuries, irritation, or serious infections. In case of an accident, seek medical assistance immediately.
- Before applying grease to the grease fittings or removing drain, level, or oil fill plugs, clean the area beforehand to prevent dirt from entering.
- Do not start the tractor in an enclosed environment without ensuring proper ventilation through open doors and windows, as exhaust gases may cause intoxication, fainting, and even death.

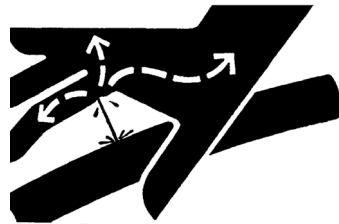

## 2.9 - Definition of responsibilities

According to NR-31 - Regulatory Standard for Occupational Safety and Health in Agriculture, Livestock, Forestry, Forest Harvesting and Aquaculture, in addition to the powers and obligations assigned to the Labor Inspection Secretariat (SIT), both the operator and the owner have responsibilities regarding safety in the use of machines.

Some of the provisions of NR-31 are presented below:

### A) Responsibilities of Jan Implementos Agrícolas S/A

- Ensure that our customers are fully satisfied with the products and services we offer.
- Provide all necessary information so that the customer can maximize the performance and durability of the Jan product.
- Provide the first owner with all essential guidance for the proper operation of the equipment, either digitally or in person. In this presentation, various information is conveyed, including demonstrations of procedures involving all parts of the implement, as well as details on operation, maintenance, warranty conditions, and other relevant aspects.



#### **ATTENTION!**

*Jan Company is not responsible for consequences arising from:*

- *Modifications to the original characteristics of the implement, as well as the installation of accessories not approved by Jan.*
- *Damage to the implement or risks to the operator's physical integrity resulting from lack of knowledge, failure to follow safety instructions, lack of skill, or negligence.*
- *Operation or movement in areas with excessive slope, whether lateral or longitudinal, or on terrain that does not provide adequate traction or support.*

**B) Responsibilities of the owner and/or operator**

- The owner, whether the operator or not, is responsible for instructing and training themselves and any person directly or indirectly involved in the use and maintenance of the implement.
- Comply with and enforce all recommendations provided in the instruction manuals.
- Keep this manual in an easily accessible location for anyone who needs to consult it.
- Maintain the implement and the instruction manuals in good condition.
- Ensure adequate working conditions, hygiene, and comfort, as well as identify and assess risks to workers' safety and health.
- Provide the necessary Personal Protective Equipment (PPE) and require its use.
- Seek information on hygiene, safety, and occupational health practices.
- Encourage and implement continuous improvements in the work environment and working conditions.
- Instruct all individuals involved in the use of the implement regarding environmental care, risks, and requirements established by current labor and environmental legislation.
- Adopt and comply with standards related to safe work practices.

**C) Recommended requirements for the operator**

- Skills: driving and operating agricultural equipment.
- Capabilities: operation and maintenance.
- Recommended training: training for operation and maintenance of agricultural machinery.
- To operate agricultural equipment on public roads, consult the traffic legislation in force in your region regarding authorization for this practice and, if permitted, verify all prerequisites and conditions, such as license category, specific permits, among others.



### D) Environmental responsibilities

- Any component of the implement, as well as fluids and other materials, when replaced, must be disposed of properly in accordance with applicable legislation in your region and the manufacturers' guidelines.
- Preserve the environment by avoiding contamination of soil, air, and water.
- To do so, properly dispose of contaminated parts and other items replaced due to wear or damage.
- If recycling cannot be carried out immediately, waste must be stored in appropriate locations until collection.

### When replacing parts and oils

- Store oil in closed containers, in a dry, ventilated area and out of reach of children or animals.
- As soon as possible, deliver the material to fuel stations or companies specialized in collection and recycling.
- Store removed parts, such as belts and hoses, in boxes and send them to appropriate collection points.

## 2.10 - Emergency procedures

Situations considered as emergencies include:

- Fire.
- Implement rollover.
- Contact with power lines: for this circumstance, proceed as indicated in item 2.6 - H.

Whenever any situation occurs that puts at risk the safety of those involved in the operation, the equipment, or even the possibility of such risk:

- Completely stop the operation, also shutting off the PTO (Power Take-Off) and the tractor.
- Remain calm and move away from the area, if possible.
- In the event of injury, provide first aid.
- Before calling emergency services, avoid crowding and gather information about the victim and the incident.
- Call emergency services, such as firefighters or hospitals.
- The person involved must receive medical evaluation, even if they appear to be physically well.

After the emergency condition and before resuming operation, eliminate the cause of the problem as quickly as possible.

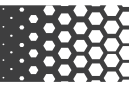

### 3.1 - Intended application of the Tanker according to the design

The Tanker is designed for transferring grains and granular fertilizers. The product is driven to the unloading tube by means of gravity.

From the base, the product can be discharged by gravity (in case of silo grain hopper), or through the unloading tube by means of a helicoid driven by the PTO.

### 3.2 - Left Hand Side / Right Hand Side Convention

The definition of LH and RH is based on the point of view of someone looking at the implement from the rear section and/or sitting in the operator's seat of the tractor.

This criterion is followed throughout the manual for describing procedures and locating Tanker components.

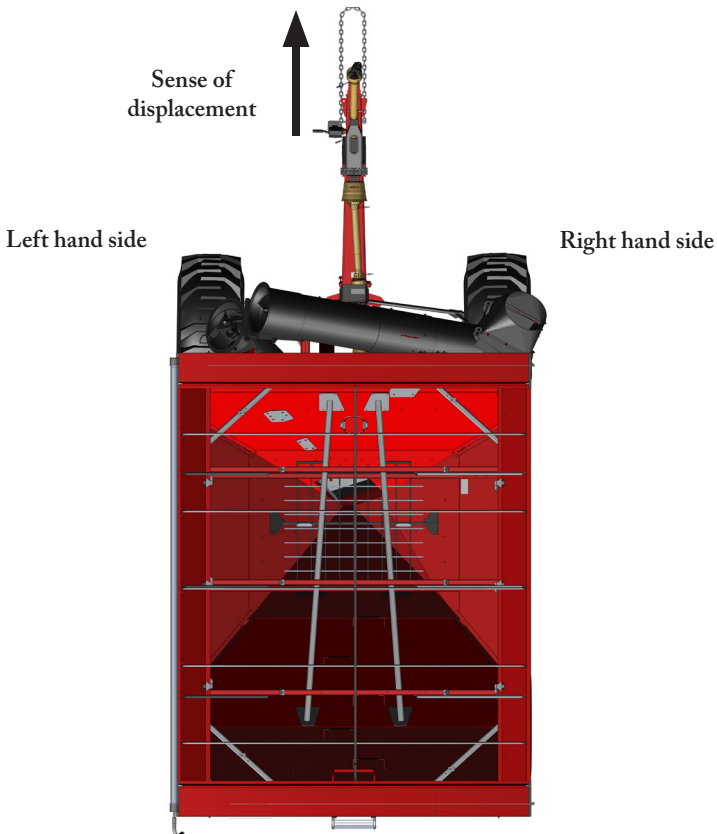

## 3.3 - Tanker identification (serial number)

The Tanker is identified by a serial number, which allows maintaining accurate records of any modifications made to the components and structural characteristics of the equipment.

The serial number (1) is stamped on a plate attached to the front section of the machine frame on the Tanker Magnu 20,000 model with one axle and on the side section of the frame on the Tanker Magnu 20,000, 25,000 and 30,000 models with two axles.

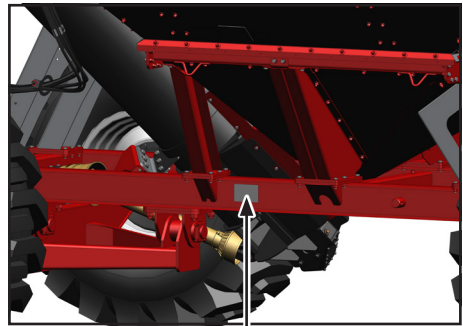
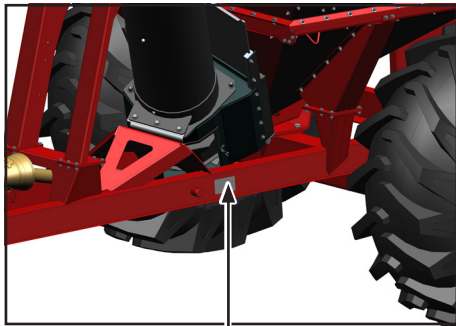

Model 20,000 with one axle

	<h1>Jan</h1>	Av. Dr. Waldomiro Graeff, 557 Cx. Postal 54 CEP 99470-000 Não-Me-Toque – RS – Brasil Fone: 54 3332 6500 Fax: 54 3332 1712 www.jan.com.br E-mail: decomp@jan.com.br
		IMPLEMENTOS AGRÍCOLAS JAN S.A. IDENTIFICAÇÃO
<div style="border: 1px solid black; padding: 5px; text-align: center;"> <span style="font-size: 24px; border: 1px solid black; border-radius: 50%; padding: 5px 15px;">1</span> </div>		

Models 20,000, 25,000 and 30,000 with two axles

### 3.4 - Available versions

Aiming to offer an option for each need, Jan offers the Tanker Magnu 20,000, 25,000 and 30,000 line with variations in the structure, construction and hopper material:

1. Carbon steel sheet, demountable, single-axle\*.
2. Stainless steel sheet, demountable, single-axle\*.

\*Single-axle version available only for the Tanker Magnu 20,000.

3. Carbon steel sheet, demountable, two-axle.
4. Stainless steel sheet, demountable, two-axle.

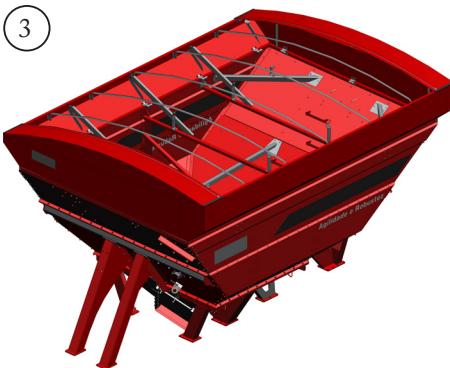
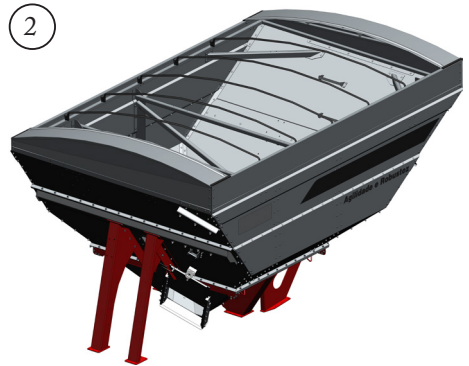
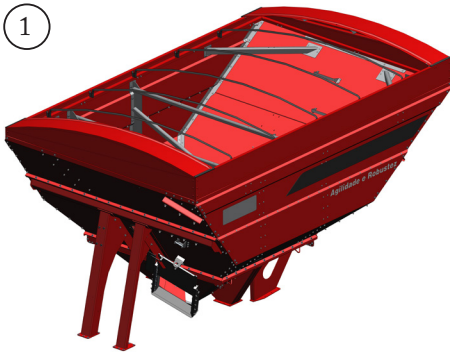

### 3.5 - Identification of components

- Hopper (1): volumetric capacity and load capacity vary according to the model and type of application. See technical specifications, item 3.6.
- Tarp support bows (2): 5 units arranged along the top of the hopper.
- Protective screen (3) for granular fertilizers (optional): protects against impurities entering the hopper, causing obstructions at the product outlet or possible damage to the unloading auger.

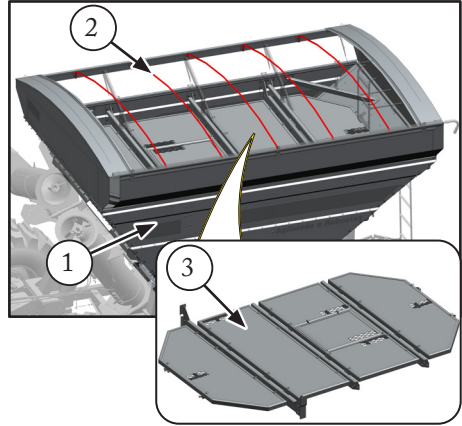

### Discharge gates and operating methods

The discharge gates (4 and 5) are of the “cassette” (slide) type that move along wooden guides:

- Gate (4) is manually controlled to regulate grain flow during gravity discharge. Opening the gate also allows access for cleaning and maintenance at the base of the discharge tube.
- Gate (5) is controlled by hydraulic cylinder (5a) from the tractor SCV (Selective Control Valve).

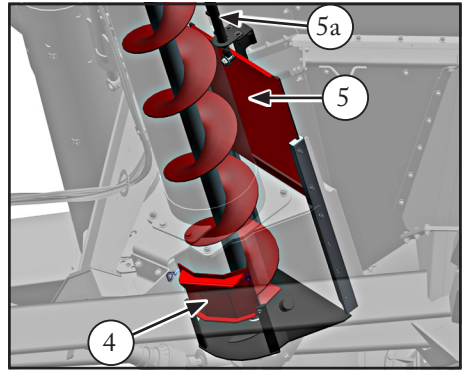

### Hitching to the tractor

- Hitch clevis (6): supplied with 2 bushings (6a) with different diameters to match the hitch pin.
- Support/mechanical jack (7), operated by a crank.

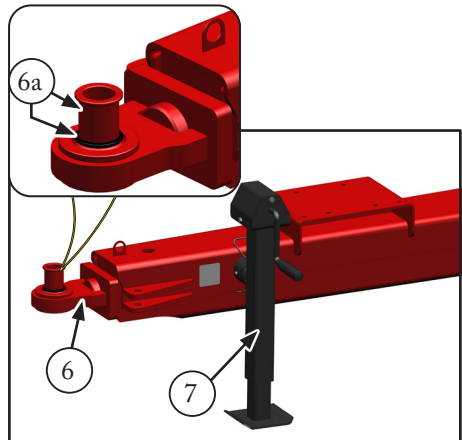

#### Discharge tube options

- The discharge tube is articulated, and the opening and closing movement is performed by the hydraulic cylinder (8a), from the tractor SCV.
- The tube is mechanically driven from the tractor PTO (at 540 or 1000 rpm), driveshafts (8d) and oil-bath gearbox (8e).
- The discharge tube (8) in the standard version is intended exclusively for grain unloading.

For this, the canvas spout (8c) at the end is used.

- As an option, the tube (8) may be of the Multi-purpose type.

In this case, the tube can be used for grains and also for granular fertilizers, whose most common application is supplying planters.

The Multi-purpose tube is internally lined with a plastic tube (8b), between the auger and the metal tube: the plastic provides lower friction for fertilizer flow.

- If the Multi-purpose tube is used for grains, use the canvas spout (8c).

For fertilizers, remove the spout (8c) and install the hopper (9) + telescopic hose (10). See item 6.3 regarding the replacement of these components.

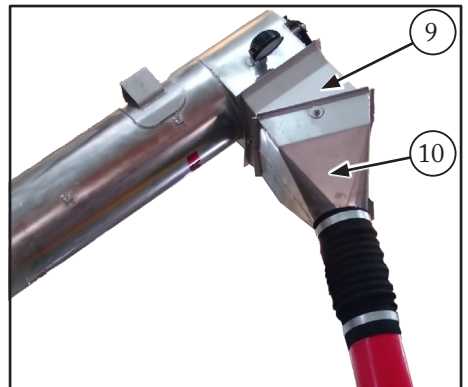
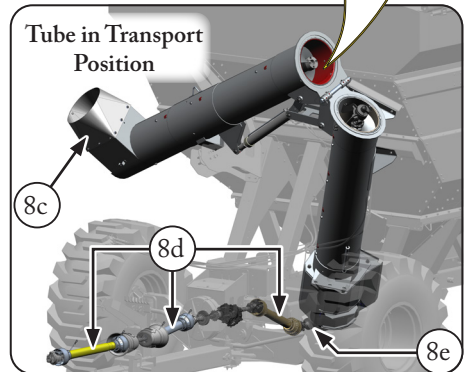
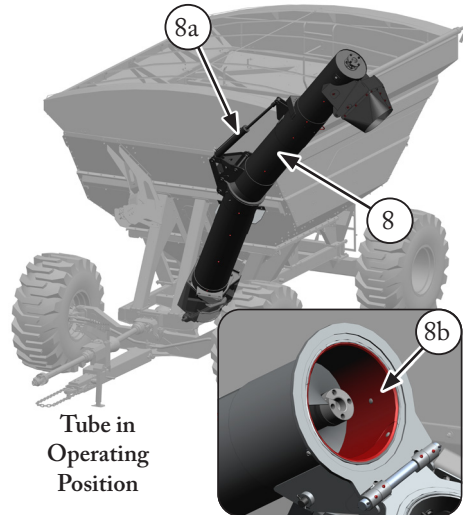

### Functional features of the discharge tube of the Tanker 20,000 to 30,000

Unloading tube	Load capacity (bags/min)	Internal diameter Pipe (mm)
Mechanical	200	Ø474,5
Multipurpose		Ø400

For more information on the technical specifications, see item 3.6.

- The discharge tube has a compensating spring mechanism (11) in the bearing housing, at the upper end of the tube, to soften the engagement of the auger sections when closing the tube.
- The work light (12) is standard for both types of discharge tube.

*NOTE: For both types of tube, unloading can only be performed with the tube fully opened.*

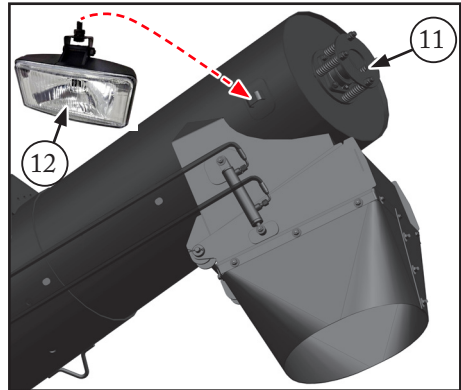

## 3.6 - Technical Specifications

Item / System	20,000	25,000	30,000
Available versions:	Demountable carbon steel single- or two-axle.	Demountable carbon steel two-axle.	
	Demountable stainless steel single- or two-axle.	Demountable stainless steel two-axle.	
Volumetric capacity (L):	20,000	25,000	30,000
Maximum recommended load capacity (kg):	15,000	18,750	22,500
Front hopper discharge:	Gravity discharge.		
	Auger-type conveying tube.		
	The discharge flow is controlled by steel plate gates with wooden guides.		
	One of the gates is manually controlled.		
	The other gate is controlled by a hydraulic cylinder, from the tractor auxiliary valves (remote control - SCV).		
PTO speed (rpm):	540 / 1000		
Required power (cv):	180 to 200		
Hitch system – drawbar type:	With hitch head. The drawbar must be of the Heavy Duty type.		
Load applied to the drawbar, with load (kgf):	1,000 (only on the single-axle model).	N/A.	N/A.
Approximate empty weight with tires (kg):	4,846 (28.1-26 MB 39).	4,970 (28.1-26 MB 39).	5,104 (28.1-26 MB 39).

## 3.7 - Dimensions

Item (mm)	20,000	25,000	30,000
A. Overall length:	1 axle: 6,900	7,970	
	2 axle: 7,970		
B. Height:	1 axle: 3,800	3,941	4,000
	2 axle: 3,712		
C. Discharge height:	1 axle: 4,260	4,340	
	2 axle: 4,340		
D. Width – with tube installed and closed:	1 axle: 3,900	4,160	
	2 axle: 4,160		
E. Track width - according to tire configuration:	2,990		
F. Minimum ground clearance according to tire configuration:	1 axle: 500	370	
	2 axle: 370		

NOTE: Dimensions valid considering the use of standard wheel assemblies (28.1-26 MB 39).

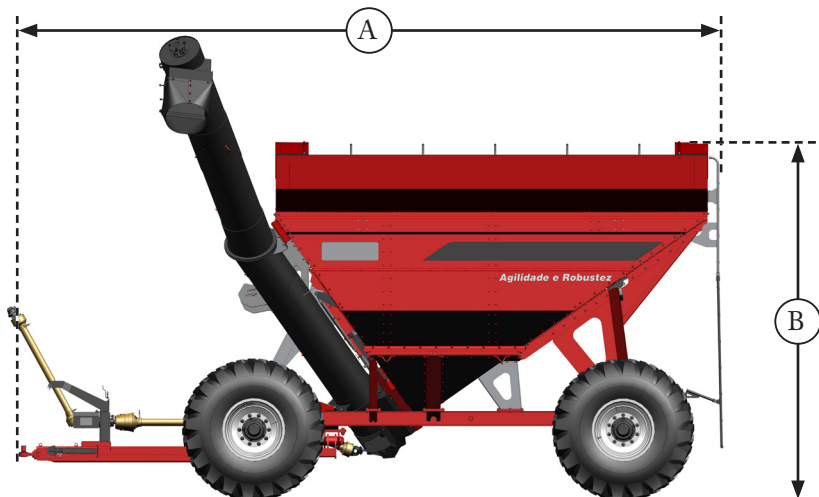

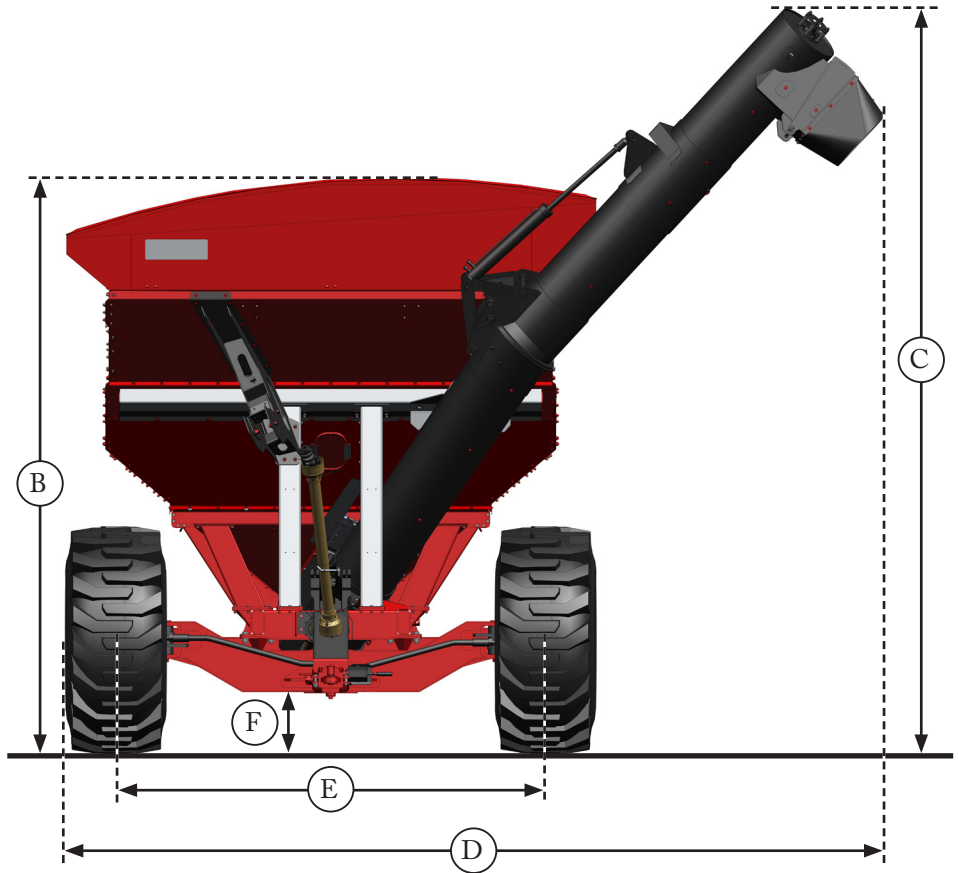

### 3.8 - Hydraulic diagram

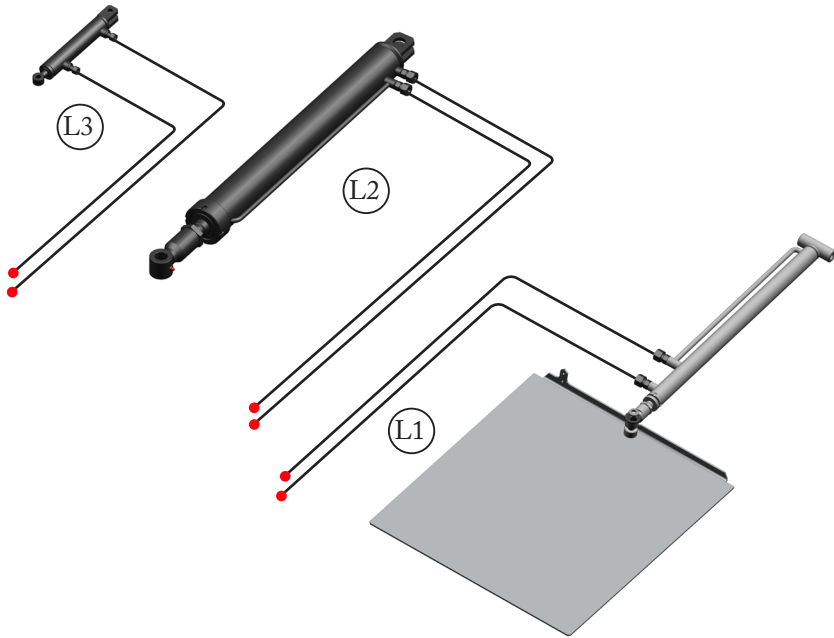

The hydraulically actuated functions are:

- L1: Control of the front dosing gate of the discharge tube.
- L2: Opening and closing the unloading tube (Mechanical and Multipurpose).
- L3: Discharge spout angle adjustment.
- See item 5.3 for more information on the Tanker hydraulic connections.

## 3.9 - Electrical diagram

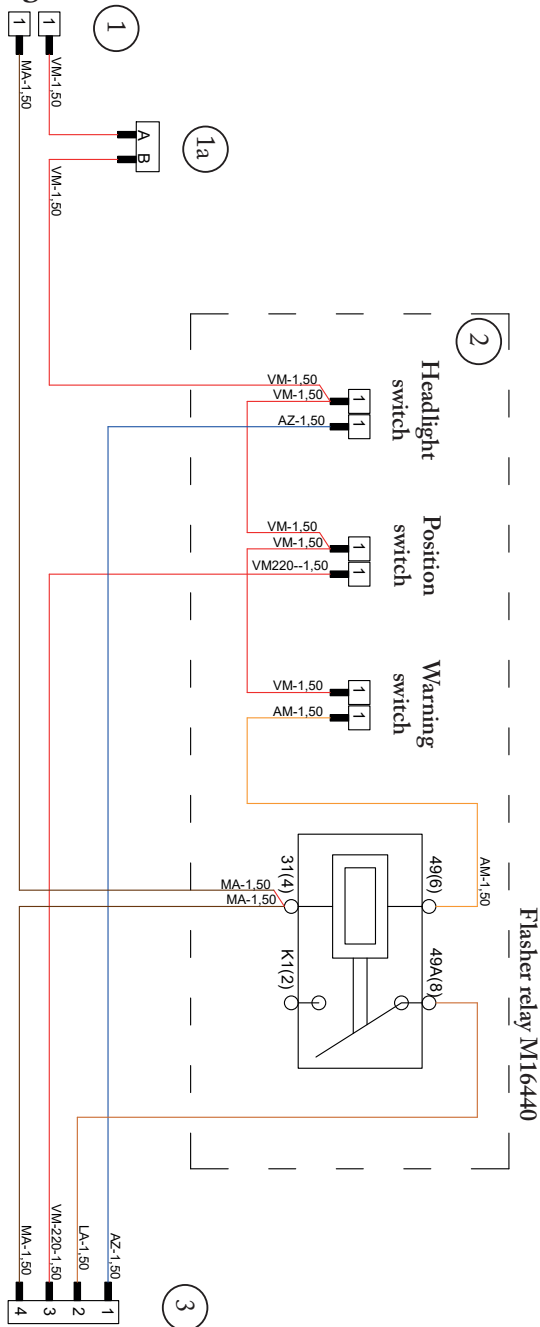

### 3.10 - Optional accessories and configurations

#### Tire options and specifications

Tire kit	20,000	25,000	30,000
Tire: 18.4-34 TM 95 (12 ply) / Wheel: DW 16-34 (flipped)	X	-	-
Tire: 23.1-26 MB 39 (14 ply) / Wheel: DW 20-26	X	X	-
Tire: 24.5-32 TM 95 (12 ply) / Wheel: DW 21-32	X	X	-
Tire: 28.1-26 MB 39 (14 ply) / Wheel: DW 25-26	X	X	X
Tire: 30.5-32 MB 39 (14 ply) / Wheel: DW 27-32	X	X	X

#### Tire and wheel specification tables

Tire 18.4-34 TM 95 (12 ply)			
Width (mm)	Diameter (mm)	Nominal capacity (kg)	Maximum pressure (psi)
479	Ø 1,638	3,375	32

Tire 23.1-26 MB 39 (14 ply)			
Width (mm)	Diameter (mm)	Nominal capacity (kg)	Maximum pressure (psi)
608	Ø 1,570	3,950	28

Tire 24.5-32 TM 95 (12 ply)			
Width (mm)	Diameter (mm)	Nominal capacity (kg)	Maximum pressure (psi)
622	Ø 1,803	4,390	24

Tire 28.1-26 MB 39 (14 ply)			
Width (mm)	Diameter (mm)	Nominal capacity (kg)	Maximum pressure (psi)
710	Ø 1,625	4,180	24

Tire 30.5-32 MB 39 (14 ply)			
Width (mm)	Diameter (mm)	Nominal capacity (kg)	Maximum pressure (psi)
775	Ø 1,874	8,500	22

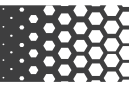

<b>Wheel / rim: DW 16-34</b>		
Center hole diameter (mm)	Number of bolts and gauges	Bolt circle diameter and hole diameter (mm)
Ø 221	8 / M22	Ø 275 / Ø 24

<b>Wheel / rim: DW 20-26</b>		
Center hole diameter (mm)	Number of bolts and gauges	Bolt circle diameter and hole diameter (mm)
Ø 221	8 / M22	Ø 275 / Ø 24

<b>Wheel / rim: DW 21 – 32</b>		
Center hole diameter (mm)	Number of bolts and gauges	Bolt circle diameter and hole diameter (mm)
Ø 282	10 / M22	Ø 335 / Ø 24

<b>Wheel / rim: DW 25 - 26</b>		
Center hole diameter (mm)	Number of bolts and gauges	Bolt circle diameter and hole diameter (mm)
Ø 282	10 / M22	Ø 335 / Ø 24

<b>Wheel / rim: DW 27-32</b>		
Center hole diameter (mm)	Number of bolts and gauges	Bolt circle diameter and hole diameter (mm)
Ø 282	10 / M22	Ø 335 / Ø 24



#### Miscellaneous accessories



**NOTE:**

*The items below are for reference only. For each Tanker model and version, optional items have specific codes. Consult your Distributor or Jan's Sales Department.*

#### Tanker 20,000 - 25,000 - 30,000:

- Protection grid kit for granular fertilizers.
- Electromagnetic clutch kit via radio control.
- Hose kit for discharge tube and gate.
- Discharge tube and gate kit with radio control Agrobartt.
- Work light kit + 10-meter wiring harness.
- Cover tarp kit (easy tarp system).
- Discharge tubes – options:
  - Mechanical
  - Multipurpose
- Spout hose for multi-purpose tube.
- Jack.
- Driveshaft kit.
- Unbraked axle.
- Hydraulic-brake axle.
- Firefighting kit.
- Flipped wheel assembly kit.

#### 3.11 - Loose items supplied with the Tanker

1. Operator's manual.
2. Rear support stand (only on the Tanker Magnu 20,000 model).
3. Rear axle (when the machine is equipped with a brake system).
4. Rear wheel hubs.
5. Tires and rims.
6. Hitch.
7. Driveshaft.
8. Hydraulic cylinder for opening the discharge tube.
9. Discharge tube rest support.

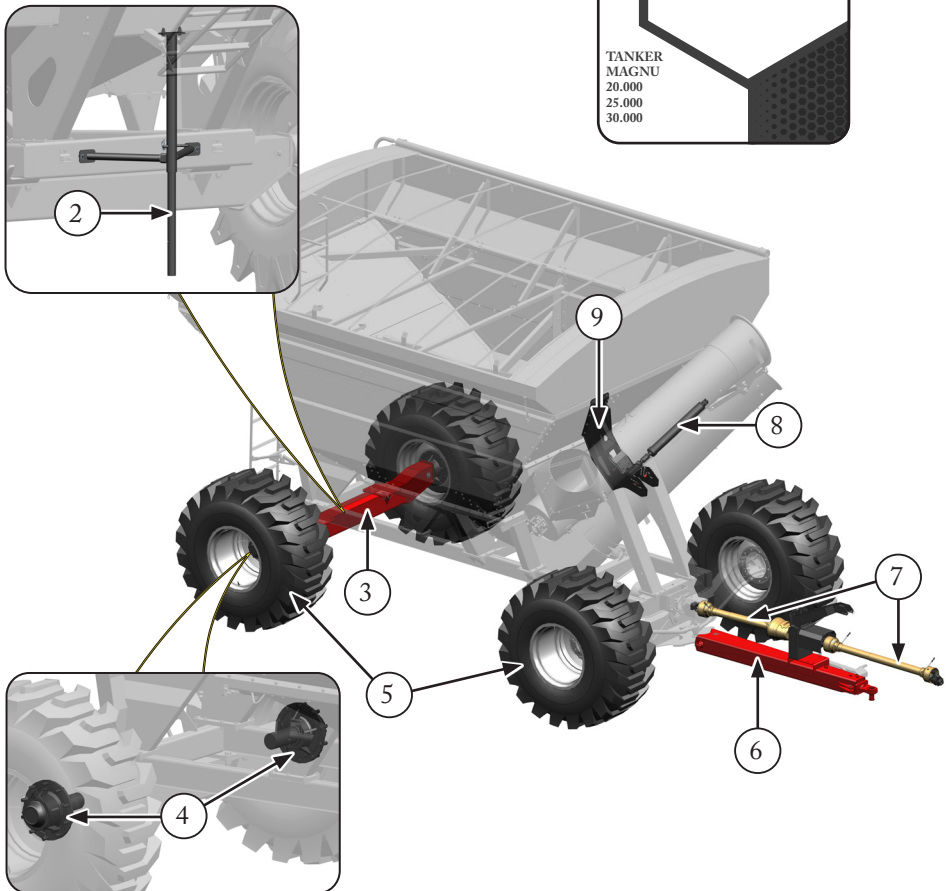



### 3.12 - Estimated service life and decommissioning

The service life of the implement cannot be precisely determined and is affected by several factors, such as:

- The care applied during use, maintenance, and preservation over the years.
- Operating conditions: number of hours worked per season and load intensity.
- Properties of the transported product.
- Check operating conditions: see item 6.3.

#### Guidelines for disposal of the implement at the end of its service life (decommissioning)

When the implement reaches the end of its service life and is taken out of operation, it is recommended to drain the oil.

- Most of the implement components are recyclable.
- Disassembly and recycling procedures must be carried out by qualified professionals, following instructions in accordance with the applicable legislation in your region or country.





### **ATTENTION!**

- *Perform assembly on a flat, firm, and level surface.*
- *Use appropriate lifting devices capable of safely supporting the weight of the components.*
- *Never stand under suspended parts.*
- *Do not improvise!*

### 4.1 - Hitch assembly

#### To assemble the driveshaft support:

- a) Position the driveshaft support (1) aligned with the holes in the hitch (2).
- b) Insert and tighten the fastening assemblies (3) as shown in the adjacent image.

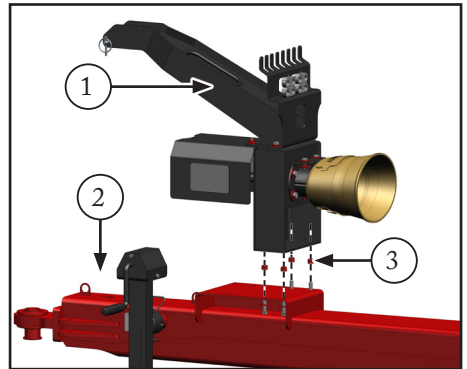

#### To assemble the hitch to the front axle:

- a) Chock the machine to prevent movement during assembly.
- b) Align the hitch (2) with the bushing (6) of the implement frame.
- c) Insert the assembly (7) into the bushing (6).
- d) On the threaded end of the assembly (7), install the castle nut (4) and insert the cotter pin (5).
- e) On the other end, secure the assembly (7) to the hitch (2) with the fastening assembly (8).

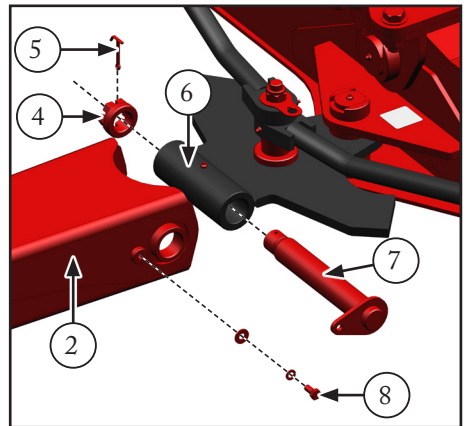

## 4.2 - Rear axle assembly

If the machine is not equipped with a brake system, axle assembly is not required.

When the Tanker is equipped with a brake system, rear axle assembly must be performed as follows:

- For added safety, engage the header to the tractor's drawbar. See item 4.1 for more information on hitch assembly.
- Raise the chassis (1) to the required height using a hydraulic jack.



### **IMPORTANT:**

*Properly support the Tanker chassis; never work on a structure supported only by the jack.*

- Position the axle (5) and secure it to the chassis (1) using 8 bolts (2), 16 washers (3) and 8 nuts (4).

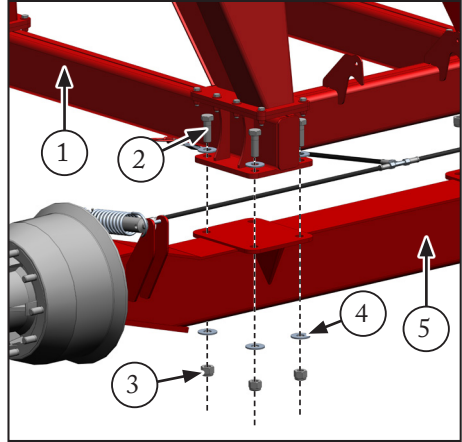

## 4.3 - Hub and wheel assembly

- Connect the front hub (1) to the steering bar (3), using the nut and washer (2): see figure below.
- Secure the rear hubs (4) to the axle (5), using the bolt, washers and self-locking nut (6).

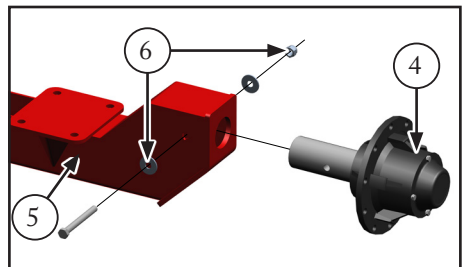
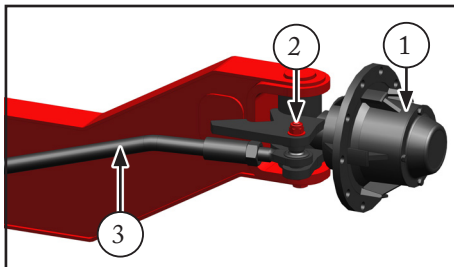

- c) Raise the Tanker axle (5) enough to allow wheel assembly.



**IMPORTANT:**

*For safety, keep the hitch connected to the tractor drawbar and use two jacks operated simultaneously.*

- d) Install the wheel assembly in the correct position:
- Fig. A: incorrect.
  - Fig. B: correct (the side with the greater rim offset must face outward).



**NOTE:**

*Mounting the rims inward (Fig. A) is used only for transporting the Tanker, when the tires are not installed.*

*See the recommended tire configurations in item 3.10.*

- e) Adjust the front wheel toe-in: see item 7.6.
- f) In case of a flipped wheel assembly, install one wheel over the other, as shown in Fig. C.

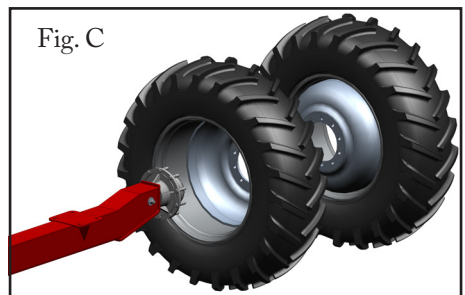
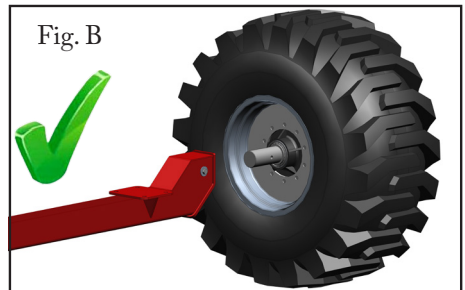
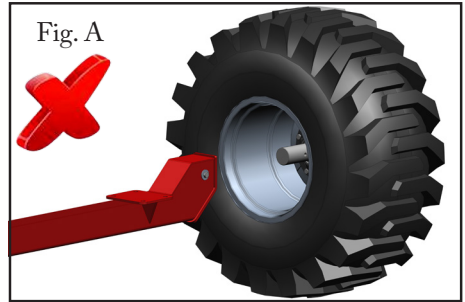

#### 4.4 - Rear support stand assembly

The support stand is present only on the Tanker Magnu 20,000 single-axle model. Perform assembly according to the points, positions, and configurations shown below:

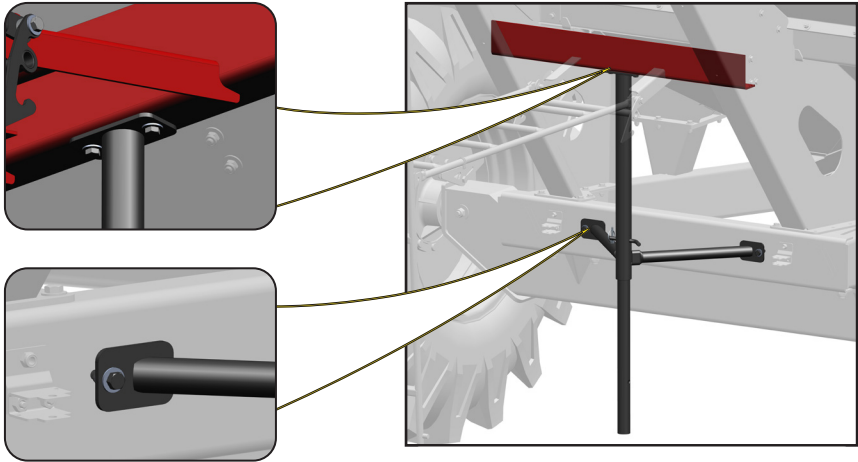

Rear support stand

#### 4.5 - Mounting the unloading pipe

- Position the discharge tube support (1) aligned with the holes in the Tanker frame.
- Secure the support assembly using the items (2): 14 bolts, 28 washers and 14 nuts.
- Adjust the support (1): see item 6.3 - C).

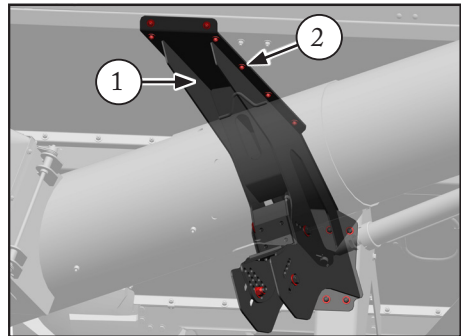

### 4.6 - Discharge tube hydraulic cylinder assembly

- Remove the locking rod (1), removing the pins and cotter pins (2).
- Install the cylinder (3) at the two points of the discharge tube with the pins (2) removed in the previous step.

*NOTE: Install the cylinder with the rod (3a) connected to the moving section of the discharge tube.*

- Install the cotter pins in the pins (2).

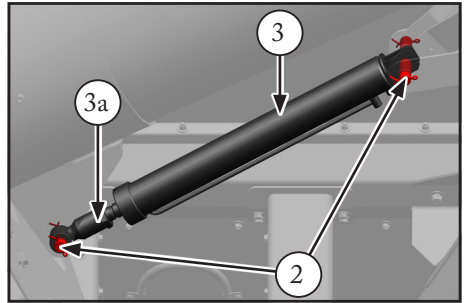
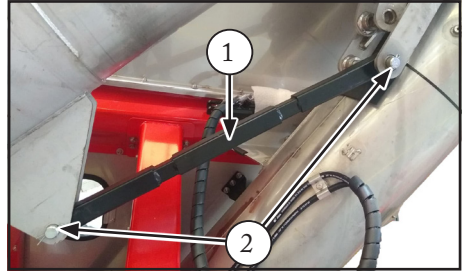

### 4.7 - Driveshaft installation

The front driveshafts (1 and 2) are supplied disassembled.

- Connect the driveshaft (1) to the intermediate shaft (3):
  - The side with the shear bolt\* (1a) must face forward.
  - Remove the bolts and nuts (1b), fit the driveshaft and reinstall the items (1b).

*\*When the shear bolt (1a) breaks due to overload, replace it with an original one or one with the same specification.*

- Install the driveshaft (2):
  - Select the shaft according to the PTO speed: 540 rpm (shaft 4) or 1000 rpm (shaft 5).
  - Connect both ends of the driveshaft in the same way used for driveshaft (1) on shaft (3).

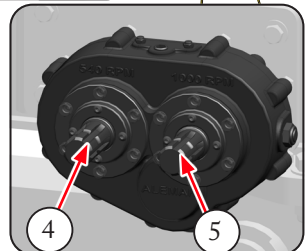
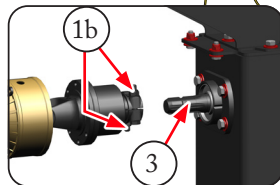
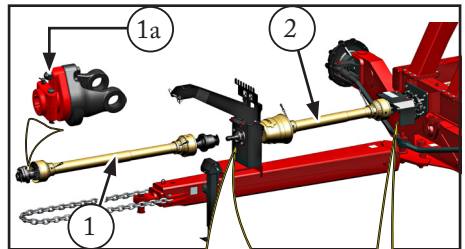



### 5.1 - Tanker hitching to the drawbar

#### A) Preliminary operations

Always after coupling the Tanker and before running it, it's advisable to check:

- Whether the tank is clean, free of materials such as bags, rags, rocks, wood, etc.
- If lubrication has been performed at all recommended points: see item 7.2.
- Whether all bolts and nuts are properly tightened and all components secured properly.
- If the discharge auger does not present imbalance. This can be verified through the vibration caused by the unloading tube when operating. In this case, the spindle coils can also interfere with the inner wall of the pipe, causing the grains to break. Seek Jan Technical Assistance.

#### B) Hitching the Tanker

##### Selection of the hitch terminal bushing (if necessary):

Depending on the diameter of the hitch pin used on the tractor drawbar, install one of the bushings (2 or 3) supplied with the Tanker on the hitch head. To replace the bushing:

- Remove the retaining ring (1) and remove the bushing.
- Install the other bushing and secure it with the retaining ring (1).

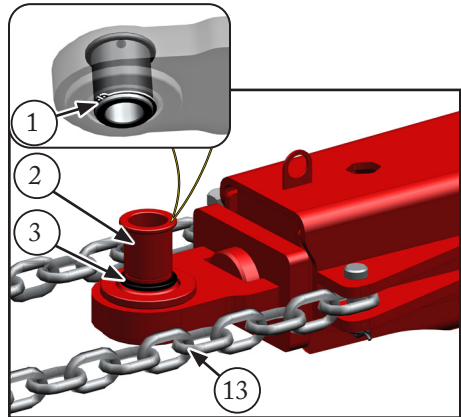

##### Tanker hitching

- Drive the tractor so that the drawbar approaches the hitch (5), in alignment.
- Turn the jack handle (6) until the hitch terminal (7) is at the same height as the drawbar (4).

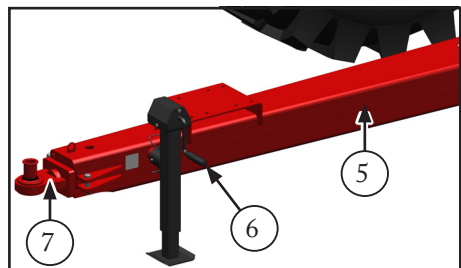

- c) Check the longitudinal leveling of the hitch: ideally, it should be as parallel as possible to the ground, observing it from the side.

If necessary, change the height of the tractor drawbar (4): refer to the respective manual, if necessary.

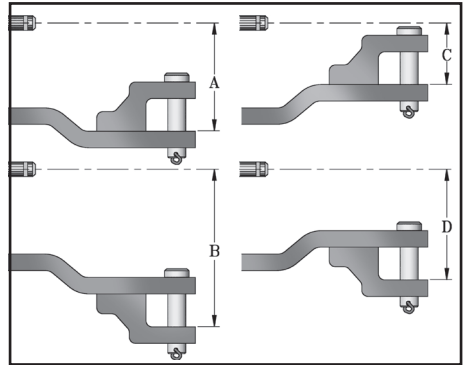

- d) Complete the tractor approach and have an assistant install the pin (8), with a locking clip (9).

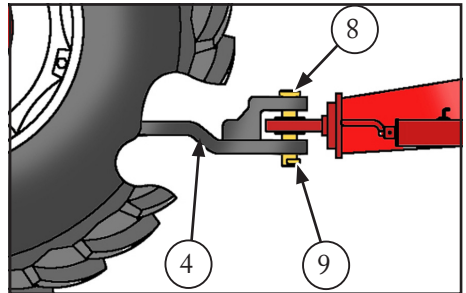

- e) Place the jack in the transport position. To do this, remove pin (10), rotate it to horizontal position - figure alongside and reinstall pin (10).

*NOTE: In both jack positions (transport and rest), always install pin (10) and the safety cotter pin (11).*

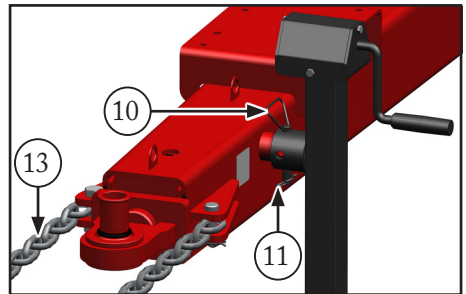

- f) Connect the driveshaft (12) to the PTO shaft: see item 5.2.

*NOTE: About the correct use of the PTO, follow the recommendations in your tractor's manual.*

- g) Connect the implement safety chain (13) to the designated chain retention point on your tractor.

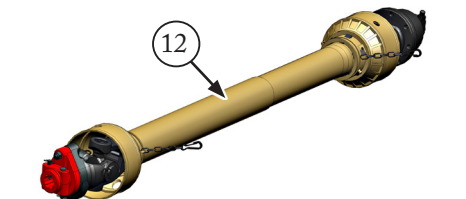

### C) Uncoupling the Tanker

Proceed in reverse to the coupling, noting the following points:

- Unhitch the Tanker on a flat and level surface, blocking the wheels for safety.
- Lower the jack to the rest position and lock it as described.

- To disconnect the hydraulic hoses (14), follow the instructions in item 5.3.

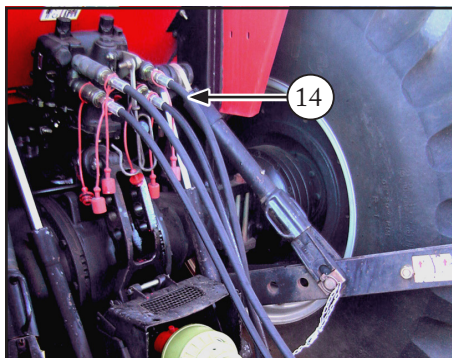

## 5.2 - Driveshaft assembly, adjustments and working angle



### NOTE:

When disconnecting the driveshaft (1), always secure it on the support (2).

At the first coupling of the Tanker to a given tractor, make sure if the drive shaft does not have an excessive length:

- Hitch the Tanker to the tractor.
- Separate the driveshaft sections: the front, tubular section (1a), and the rear, solid shaft (1b).

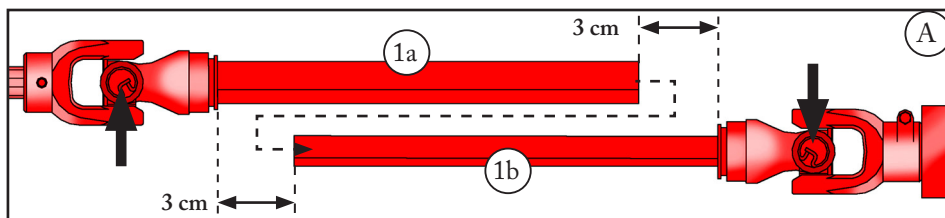
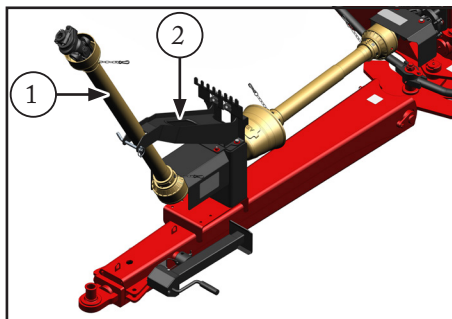

- Connect the front section (1a) to the PTO shaft; the rear section (1b) must remain connected to the Tanker.
- Place the driveshaft sections side by side, as shown in Fig. A.
- Check that there is a minimum clearance of **3 cm** at each end; if the clearance is less than **3 cm**, mark the tube (1a) and the shaft (1b) at the points where they must be cut.
- Cut the tube (1a) and the shaft (1b) to the same length.



- g) Using a file, remove burrs resulting from the cuts and lubricate the parts with grease.



### NOTE:

- *The driveshaft must not operate at an angle greater than 30°.*
- *On square-profile tube and shaft driveshafts, the yokes (3) must be assembled aligned.*

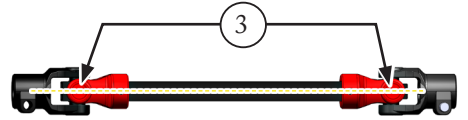
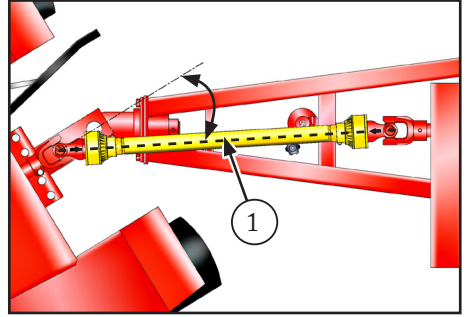

### 5.3 - Hydraulic hose connection

- a) Turn off the tractor engine and relieve any residual pressure in the hydraulic system by moving the remote control levers forward and backward several times.
- b) Remove the caps (1) from the hoses and from the female couplers (L1, L2 and L3) of the tractor remote control.
- c) Make sure that the hose ends and the outlets (L1, L2 and L3) are clean.
- d) Connect the hoses to the selected control:
- L1. Gate opening cylinder hoses: double-acting.
  - L2. Discharge tube opening and closing cylinder hoses: double-acting.
  - L3. Discharge spout angle adjustment cylinder hoses: double-acting.

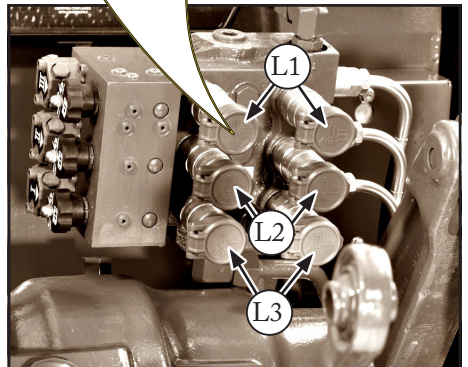
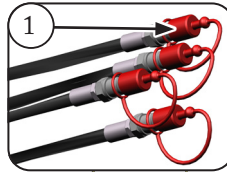

### To disconnect the hoses

- a) Shut off the tractor engine and move the remote control levers in both directions, to relieve any residual system pressure. Do not attempt to remove the hoses from the remote control while there is pressure in the circuit.
- b) Disconnect the hoses (1) from the outlets (L1, L2 and L3), pulling them firmly.
- c) Reinstall the protective caps on the couplers.
- d) Place the hoses (1) on the support on the implement hitch, preventing them from coming into contact with the ground, exposed to dust and moisture.



### **ATTENTION!**

- *Use caution when handling hydraulic oils. If there is still pressure in the hoses, relieve it before making any connection. To do so, press the check valve located at the end of the hoses against the bottom of a clean container, taking care to protect yourself from the oil jet that may be expelled.*
- *Contact with hydraulic oils may cause skin and eye irritation. Ingestion or inhalation may cause nausea, dizziness, or discomfort. If any of these symptoms occur, seek medical attention.*
- *Refer to Chapter 2 for further safety information.*

### 5.4 - Electrical connection

1. Discharge tube work light cable.
  2. Discharge electromagnetic clutch cable.
  3. Main electrical power supply: connected to the tractor battery.
- a) Using plug (4), connect the power supply cable (5) to the socket under the panel as shown.

*NOTE 1: Plug (4) is foolproof.*

*NOTE 2: When disconnecting the plug, never pull it by the cable (5), as warned on the decal.*

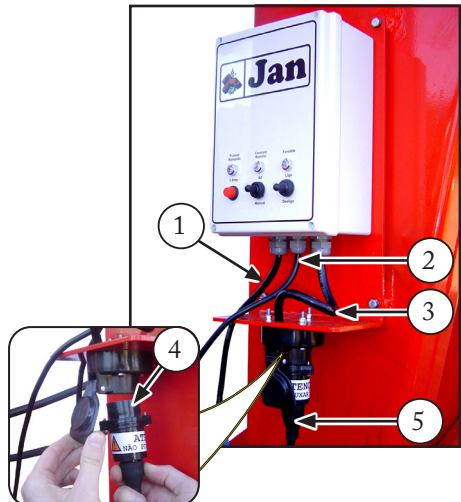

- b) In the tractor, attach power plug (6) in a convenient location. Refer to the tractor manual for guidance in this regard.
- c) Secure the cable (5) to the remote control hoses using plastic ties.
- d) Connect the cables from socket (6) to the tractor battery terminals:
  - Blue cables (X and Y): on positive terminal (+). *These cables are equipped with 10 A fuses (8) for electrical system protection.*
  - Black cable (Z): to the negative terminal (-).
- e) Connect plug (7) to socket (6): the system is ready for operation.

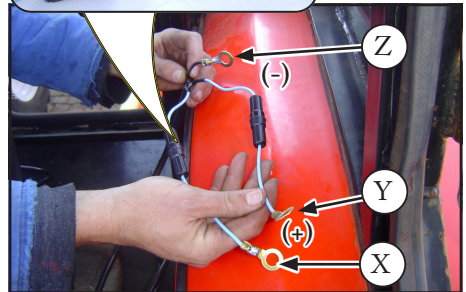
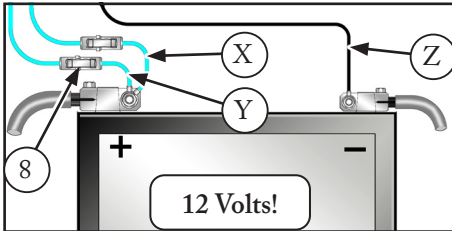
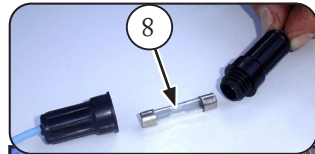
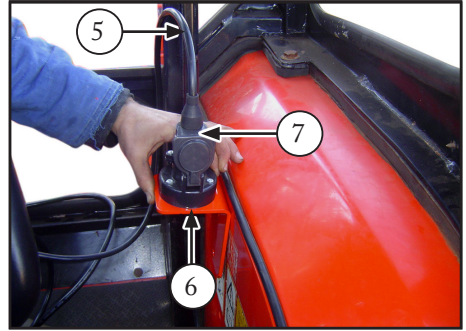



## 6.1 - Using the power take-off

- The Tanker has two speed options, 540 and 1000 rpm. The rotation selection is made in the box (1).
- Always keep the tractor aligned with the Tanker, so that the driveshaft angle does not exceed 30°.
- Only engage the PTO during Tanker operation, that is, always disengage it during maneuvers and travel.

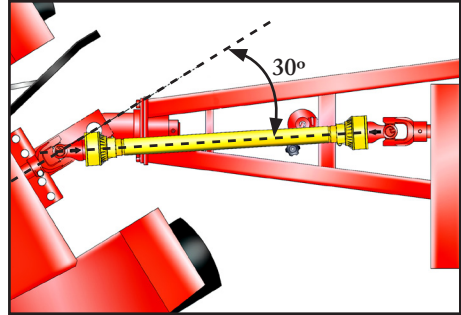

### **ATTENTION!**

*Never perform speed selection with the driveshaft coupled to the tractor PTO! Keep the driveshaft disconnected from the tractor PTO throughout the entire selection process.*

### A) Selection for the model without electromagnetic clutch

Before starting the procedure, make sure the machine is completely stopped, with the jack in the rest position.

- Based on your tractor PTO speed, check which shaft (2 or 3) the driveshaft (4) must be connected to: see the indication on the decal (5).

If necessary, change the speed:

- Disconnect the driveshaft (4) and then connect it again to the shaft corresponding to the selected speed.

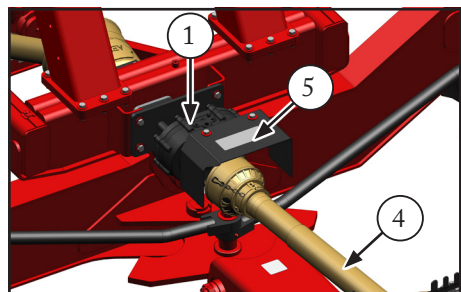
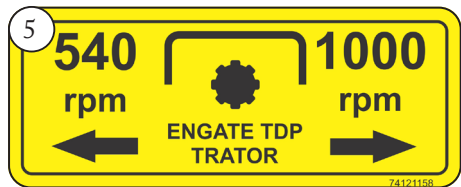
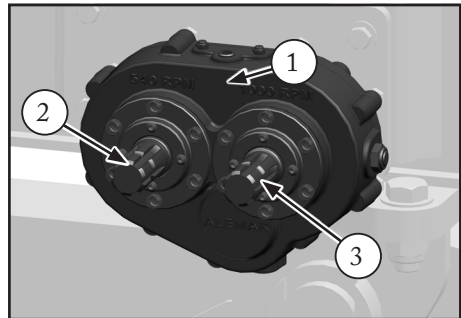

### B) Selection for the model with electromagnetic clutch

- a) Based on your tractor PTO speed, check where the clutch (6) must be positioned: see the indication on the decal (5).

If necessary, change the speed:

- b) Remove the fastening assemblies (7): there are 4 units.
- c) Loosen the Allen screw (8) and disconnect the clutch (6) from the shaft to which it is connected.
- d) Move the support + clutch assembly to the position corresponding to the other shaft: engage the chain coupling and install the fastening assemblies (7).

- e) Retighten the Allen screw (8).

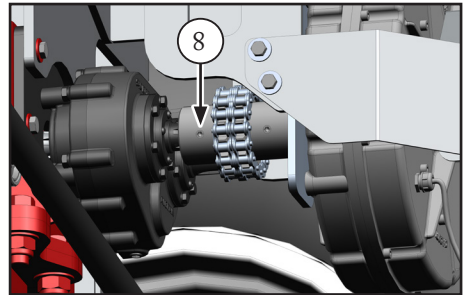
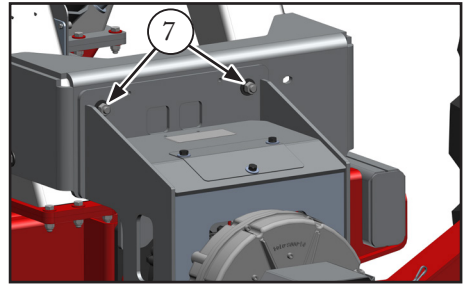
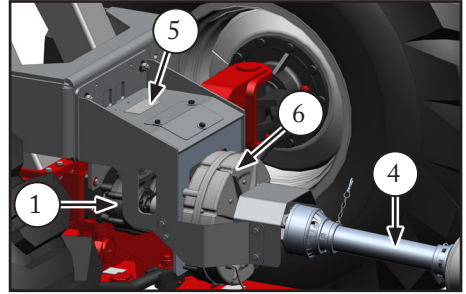

### 6.2 - Tanker loading

Bring the Tanker close to the supplying unit (harvester or other), so that the discharge occurs without loss of grains.

To distribute the load, move the Tanker or supplying unit to and fro.



## 6.3 - Tanker unloading: methods and procedures

### A) Discharge by gravity

This option is used mainly for discharge silo grain hoppers.

Additionally, in case of obstruction or clogging of the discharge auger tube, open gates (1 and 2) and unload the grain from below.

*NOTE 1: In both cases, discharge is performed with the power take-off shut off.*

*NOTE 2: By opening gate (2), access is provided for inspection and maintenance of the auger and/or for removing remaining grain at the base of the auger.*

To perform unloading through gate (2):

- a) Fully open gate (1) using the tractor SCV.
- b) Loosen the wing bolts (2a) and regulate the product flow by adjusting the opening of gate (2).

*NOTE: The gate can be locked in any position by tightening the bolts (2a).*

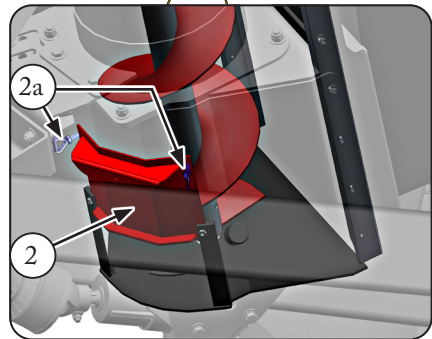
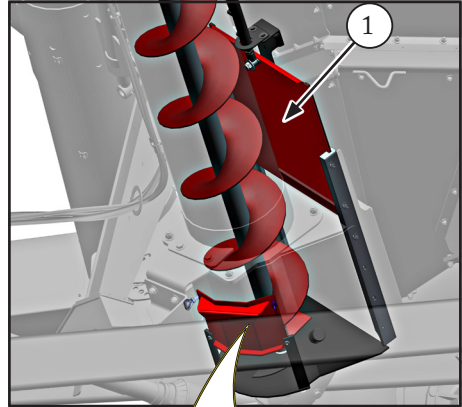

### B) Grain unloading through the discharge auger tube

#### Panel (2) identification:

- A - Indicator LED: lights up in case of fuse (D) failure; in this case, replace it with a 3 A fuse.
- B - “RF” (Radio Frequency) indicator LED: lights up when enabled for use with the remote control (3), via selector (E).
- C - Exhaust tube light indicator LED on.
- D - Fuse (3 Amps).
- E - Operating mode selector:
  - Up - RF (Radio Frequency): enables the remote control (3). In this condition, operate the discharge auger tube using button (G) on the remote control. To stop, press button (G) again.
  - The discharge tube is driven by the electromagnetic clutch (1): see more information in item 6.7.
  - Center position: OFF.
  - Down - Manual: disables the remote control and activates the discharge auger tube. To turn it off, return the selector to center position.
- F - Work light switch.

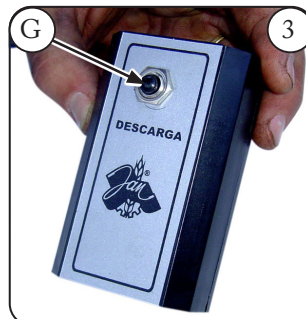
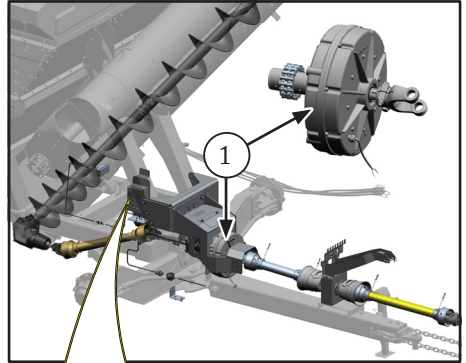

### Procedure

- Position the Tanker so that the discharge auger tube is over the unloading point. The grain flow direction can be changed by the hydraulic cylinder (4), through the tractor SCV.

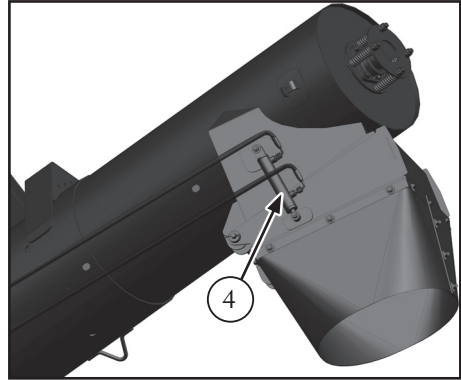

### To operate the unloading tube - Tanker without electromagnetic clutch

- a) Adjust the rotation speed selection, if necessary: see item 6.1.
- b) Engage the tractor PTO.

### To operate the discharge auger tube - Tanker with electromagnetic clutch (1) - Optional for all models

- a) Adjust the rotation speed selection, if necessary: see item 6.1.
- b) Engage the tractor PTO.
- c) To start unloading, there are 2 options:
  - Use the panel (2): to start unloading, move switch (E) down. To switch off, move the switch to the center position.
  - Use the remote control (3): press button (G).

### C) To use the multipurpose tube with fertilizers

It is necessary to replace the canvas spout (6) with the hopper (8) + flexible hose (9).

#### Procedure:

- a) Remove all fastening assemblies (4) and plates (5) that secure the canvas spout (6) to the unloading tube.
- b) In place of spout (6), install the hopper (8) + flexible hose (9) assembly onto the discharge auger tube.
- c) Perform the assembly using fastening items (7), in holes (10) of the discharge auger tube:
  - Bolts + small flat washer + bushing (7a)\*: installed from the inside.
  - Large flat washer + small flat washer + self-locking nut: installed from the outside.

*\*The bushing (7a) serves as a stop to allow the hopper (8) to oscillate freely.*

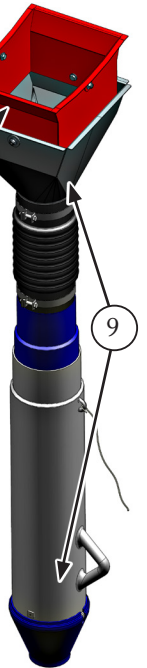
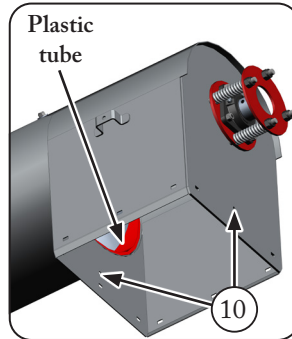
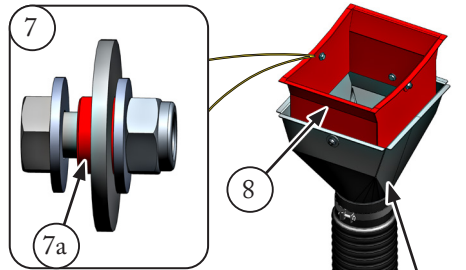
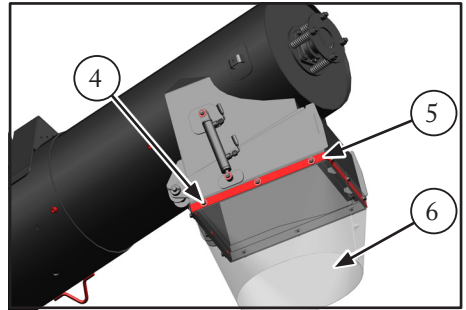

**NOTE:**

Ensure that support (2) is properly adjusted: the discharge auger tube (3) must be fully supported to prevent vibration or oscillation in the closed position.

To adjust, loosen or remove the 4 bolts (1) and reposition the support assembly (2) as required. Reinstall and/or retighten the bolts.

Also check that the support damping plates (4) are in good condition and properly secured: damping prevents deformation and cracking of tube (3).

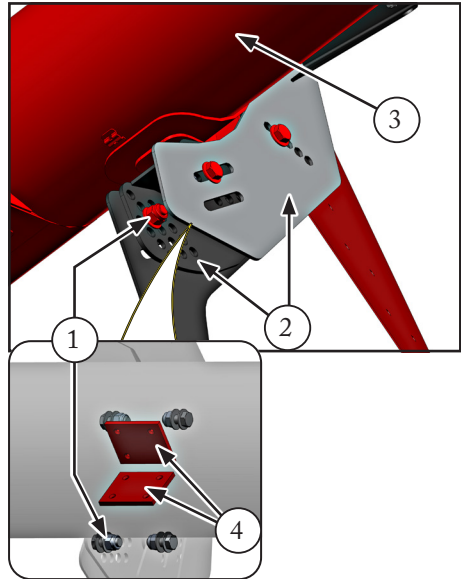

## 6.4 - Use of the Easy Tarp system (optional)

Refer to the following figure:

- The Easy Tarp system allows for quick tarping. The tarp (2) is used to cover the product hopper, protecting it from weather before and during operation, ensuring material preservation.
- In the open position, tarp (2) remains rolled over the left edge of the hopper, supported by three brackets (1).
- The transition from the open to the closed position is carried out by means of the extendable shaft (9), the elastic joint (8), and the crank (11).
- The tarp rolls and unrolls over the ramps (3) and bows (6).
- Keep strap (5) tensioned using the ratchet tensioner (4).

### Procedure to cover the hopper (tarping)

- Remove the crank (11) from the LH coupling (10), removing the pin.
- Unroll the tarp (2) by turning the crank (11) clockwise to the end of travel.
- Retract the extension (9) with the crank and then secure the crank to the RH coupling (12), installing the pin.

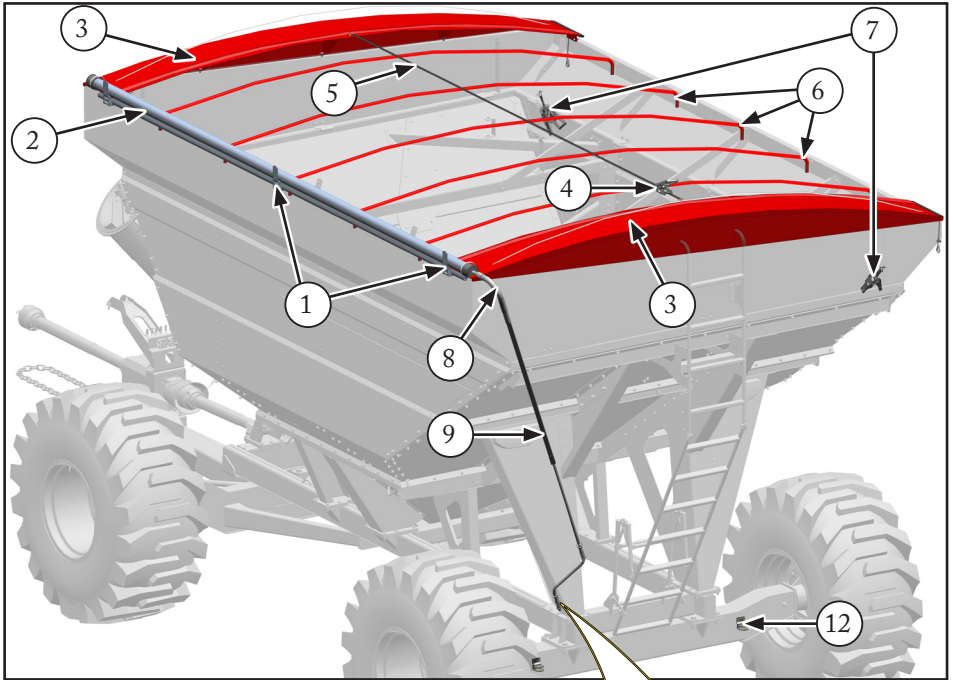

### To uncover the hopper (remove tarp)

- a) Disengage the crank (11) from the RH coupling (12) and turn it counterclockwise until the rolled tarp rests on the supports (1), on the LH side.
- b) Engage the crank (11) again in the coupling (10) and install the pin.



#### **IMPORTANT:**

- Do not walk on the tarping system.
- Do not travel at high speed with the hopper open (uncovered).
- Do not load or unload the hopper without fully uncovering it.
- Do not release the ratchet tensioners (7): they must keep the cables tensioned to ensure proper system operation. Adjustment is performed during system assembly.

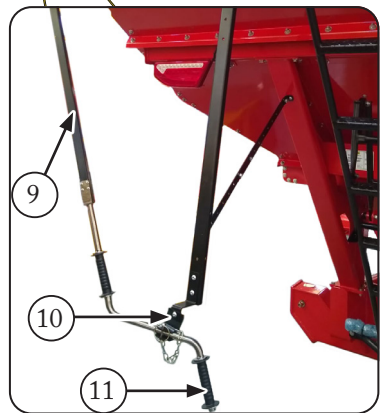

## 6.5 - Use of the firefighting kit (optional)

This firefighting kit has limited capacity and is suitable only for use in the initial stages of fire (incipient fires).

Use of the kit does not replace professional firefighting systems. For situations in which the fire has developed or is out of control, the use of appropriate means with greater capacity is mandatory, as well as contacting the competent emergency services.



### **ATTENTION!**

*If the fire shows signs of spreading, high intensity, or risk to people's safety, immediately stop the firefighting attempt and contact emergency services and use suitable equipment, such as fire trucks.*

The Kit is installed on the rear section of the Tanker structure, under the chassis.

The system water pump is driven by a hydraulic motor from the tractor SCV.

### A) Components

1. Tank: has a cap, filter, water level sight glass and drain plug. The tank has a capacity of 400 liters.
2. Water pressure regulating valve.
3. Tank valve.
4. Nozzle.
5. Reel.
6. Hydraulically driven water pump.
7. Hydraulic hoses: connected to the tractor SCV.

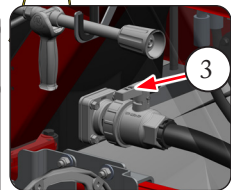
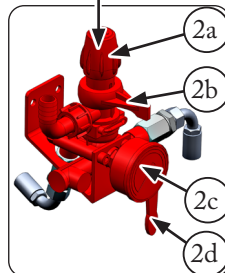
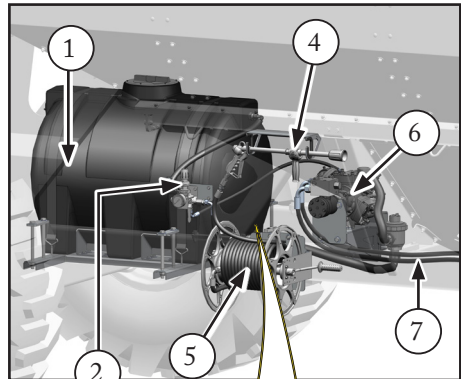

### B) How to use

#### Before starting operation:

- a) Fill the tank (1) with clean water.
- b) Connect the kit hydraulic hoses (7) to a continuous-flow outlet of the tractor SCV.
- c) Open the valves (2d and 3).

#### When using the firefighting kit:

- d) Activate the water pump using the respective tractor SCV lever.
- e) Accelerate the tractor engine.
- f) Release the lock (5a) and pull the nozzle (4) with the hose to the fire location.
- g) Activate the nozzle (4) by pressing the trigger (4a). The trigger can be locked open with the lock (4b).

- Adjust the water spray pattern by moving the lever (4c) forward or backward: see indicator arrow.
- If necessary, change the pressure using the knob (2a) of the regulating valve:

1. Release the lock (2b).
2. Turn the knob (2a): clockwise increases the pressure and vice versa: the adjusted pressure is indicated on the pressure gauge (2c).
3. Retighten the lock (2b).
- h) After completing the operation, switch off the water pump and retract the hose by turning the crank (5b). Then, reengage the lock (5a).

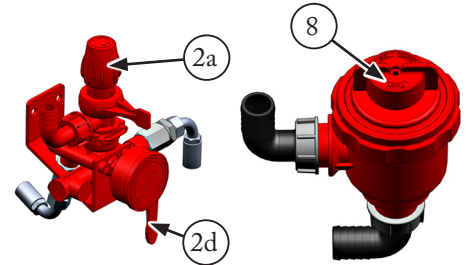
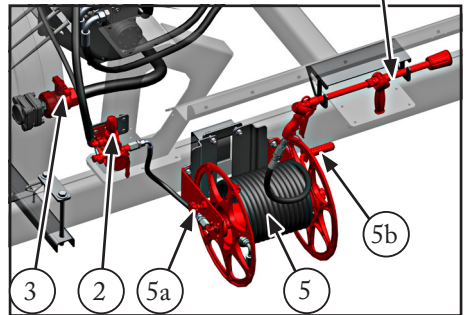
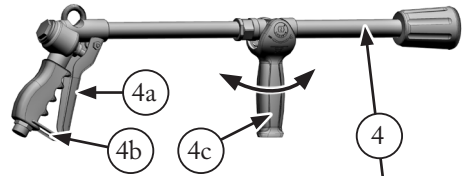
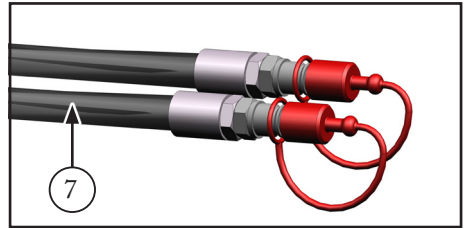

- b) Remove the filter cap (8): press it and turn it clockwise.
- c) Remove the filter and wash it.
- d) Reinstall the filter and cap (8): push it in and turn it counterclockwise.
- e) Open the valve (3).

### C) Maintenance

#### Cleaning the water filter

- a) Close the valve (3).

### General care

- Check the tank before the beginning of the harvest season for cracks, leaks, and other damage.
- Always keep the protective screen of the tank filler neck clean.
- Inspect the hydraulic connections and hoses.
- Perform a functional test of the kit.

### 6.6 - Using the hydraulic brake (optional)

The drum-type brake system is hydraulically operated by the control system in a single action way and by the cylinders (1), which act simultaneously on the rear wheels.

The return occurs by the action of the spring (2).

#### To use the brake:

- Connect the hose (3) to one line of the tractor SCV and open the valve (4).
- To actuate the brakes, actuate the tractor SCV lever smoothly and progressively, holding it in position.
- To end the braking action, simply release the lever: the spring (2) returns the cylinder.
- When disconnecting the hose (3), close the valve (4).

*NOTE: If it is necessary to keep the brake applied with the Tanker unbitched from the tractor, apply the brake, close the valve (4) and disconnect it from the tractor.*



#### **ATTENTION!**

*Opening the valve in this situation will interrupt braking.*

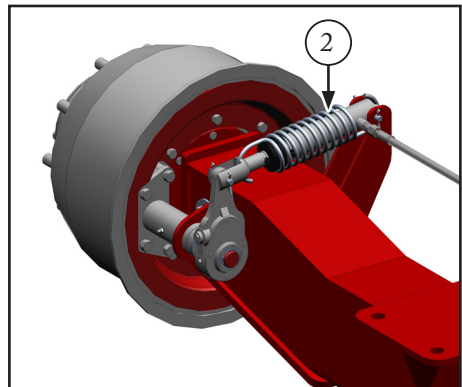
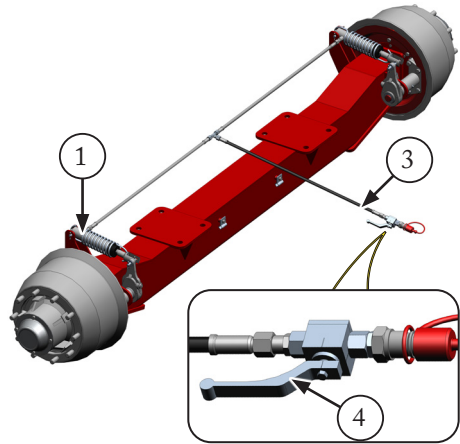

### 6.7 - Electromagnetic clutch kit (optional)

With the electromagnetic clutch (1), it is possible to turn the discharge flow on or off. The electromagnetic clutch is operated by the control panel (2), the shape of which depends on the position of the selector (E):

- Center position: OFF.
- Up - RF (Radio Frequency): enables the use of the remote control (3). In this condition, actuate the grain discharge tube through button (G) on the remote control (3). To stop, press button (G) again.
- Down - Manual: disables the remote control and activates the discharge auger tube.
- To turn it off, return the selector to center position.

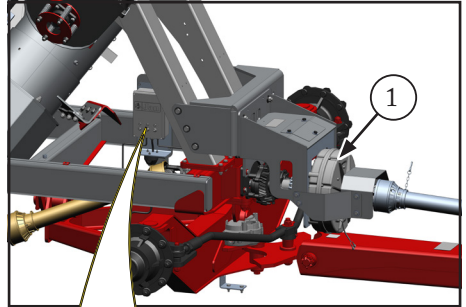

#### General identification:

- A - Fuse indicator LED (D) blown. In this case, replace it with another 3 Amp one.
- B - Radio Frequency indicator LED activated for remote control use, through selector (E) - (See description above).
- C - Exhaust tube light indicator LED on. The power button is item (F).

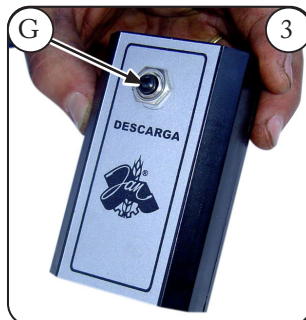

## 6.8 - Agrobartt kit (optional)

### System operation

With the AgroBartt panel it is possible to control the discharge flow and control the position of the second stage of the discharge tube. The system can be controlled by panel (1) or control (2).

### Panel controls (1):

- A - LED indicating that the panel is connected to the battery.
- B - LED indicating that the system is switched on.
- C - LED indicating that the spotlight (1a) of the discharge tube is switched on.
- D - Spotlight switch (1a) of the discharge tube:
  - Up: On.
  - Down: Off.
- E - System main switch:
  - Up: On.
  - Down: Off.
- F - Discharge flow controller:
  - Up: Increases flow.
  - Down: Decreases flow.
- G - Discharge tube movement lever:
  - Up: Operation.
  - Down: Rest.

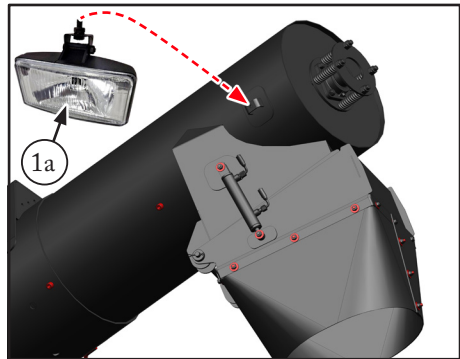
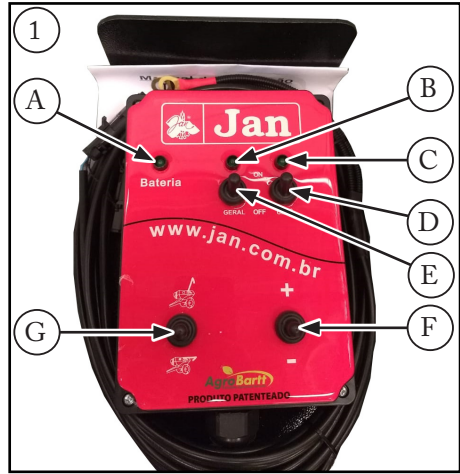

### Remote control (2):

- H - Opens the discharge tube.
- I - Closes the discharge tube.
- J - Opening (+) and closing (-) control for the discharge tube flow gate.

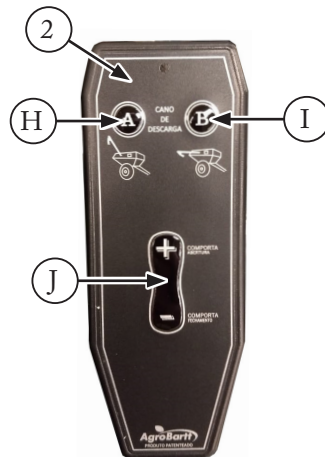

## 7.1 - Periodical maintenance chart

Maintenance item	Every 10 h or daily	Every 50 h or Weekly	Every 200 h or monthly	Every 1000 h or annually	See item:
<b>General maintenance items</b>					
Lubricate all grease fittings.	X				7.2
Check how tight and fastened nuts and bolts are, and in which condition the general components are.	X				-
Check tire inflation pressure.		X			7.4
Disassemble, clean, inspect and lubricate the wheel hubs.				X	7.7
<b>Lubrication of the discharge tube transmission gearbox and rotation selection gearbox: see item 7.3</b>					
Check the oil level:			X		
Change the oil:	<ul style="list-style-type: none"> <li>• First change: at 200 operating hours.</li> <li>• Periodic changes: every 600 operating hours.</li> </ul>				
<b>Implement preservation during inactive periods</b>					
After the operating season, prepare the Tanker for the inactive period (off-season) following the measures described in item 7.9.					

## 7.2 - Grease lubrication (daily)

### A) Recommended grease types

Manufacturer	Specified product
Ipiranga	Ipflex 2 (Used at the factory)
Atlantic	Litholine MP 2
Shell	Retinax or Alvania EP 2
Esso	Beacon EP 2
Petrobrás	Lubrax GMA-2
Texaco	Multifak MP 2 or Marfak

## B) Identification of grease lubrication fittings



**IMPORTANT:**

*Before applying grease, clean the grease fittings.*

- |  |  |
|--|--|
| 1. Discharge auger tube hydraulic cylinder rod: 1 fitting. | 6. Transmission support bearings (when not equipped with the electromagnetic clutch): 1 fitting. |
| 2. Unloading tube articulation: 4 fittings.                | 7. Hitch: 5 fittings.  |
| 3. Front hub axles: 1 grease fitting on each               | 8. Discharge auger drive gearbox: 1 fitting.   |
| 4. Coupling terminal: 2 fittings.                          | 9. Unloading tube end bearing: 1 fitting.  |
| 5. Driveshafts: 1 fitting in each crosshead.               |  |

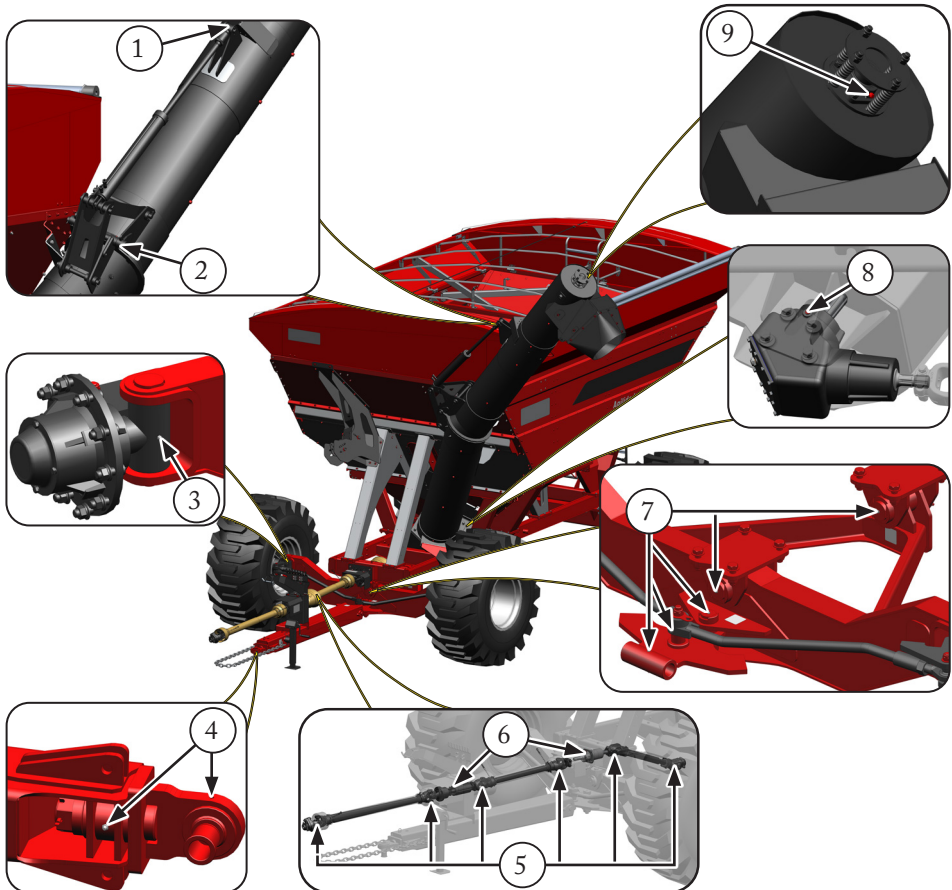

### 7.3 - Lubrication of the transmission and rotation selection gearboxes

#### A) Recommended oils

Classification: SAE 140 - API GL 4

Manufacturer	Specified products
Ipiranga	Ipitur AW 68 (Used at the factory) Ipirgerol SP SAE 140
Texaco	Universal EP SAE 140 Multigear EP SAE 85W 140 Multigear STO SAE 85W 140 Multigear LS SAE 85W 140 Meropa EP 320
Shell	Spirax AX SAE 85W 140 Spirax G SAE 140 Spirax ST SAE 85W 140
Esso	Gear Oil GX 85W 140 Gear Oil GX 140 Gear Oil GP 140
Petrobrás	Lubrax TRM-5 SAE 140 Lubrax GOLD 85W 140 Lubrax GL-5 SAE 140 Lubrax GL-5 SAE 85W 140
Petronas	PAKO R320 EP

#### B) Oil capacity

- Transmission gearbox capacity: 2.5 liters.
- Rotation selection gearbox capacity: 0.8 liters.

#### C) Oil level check

With the Tanker level, the oil level must reach the sight glass (2).

To top up the oil, remove plug (1) and fill the gearbox until the oil reaches the sight glass (2).

*NOTE 1: Plug (1) is equipped with a breather. Keep it clean at all times.*

*NOTE 2: When topping up the oil, always use oil of the same brand and classification.*

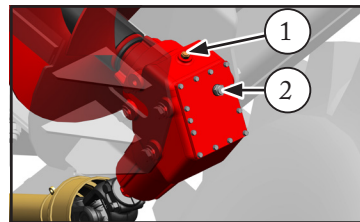

**Transmission gearbox**

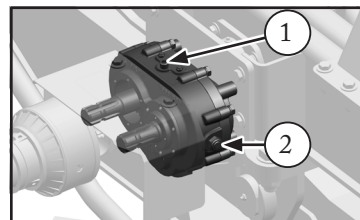

**Rotation selection gearbox**

## D) Oil change

### Transmission gearbox:

- With the Tanker level, place a collection container under the gearbox.
- Remove bolts (4) and cover (3).
- Remove the oil residue and impurities from the bottom of the gearbox using a clean cloth.
- Check the condition of gasket (5): replace it if it is not in perfect condition.
- Install the cover (3) with the gasket (5) and secure it with the bolts (4).  
*NOTE: Tighten the bolts in a crisscross pattern and in stages to avoid deforming the cover.*
- Remove the plug (1) and refill the gearbox with the recommended oil until the level reaches the sight glass (2). Reinstall the plug (1).

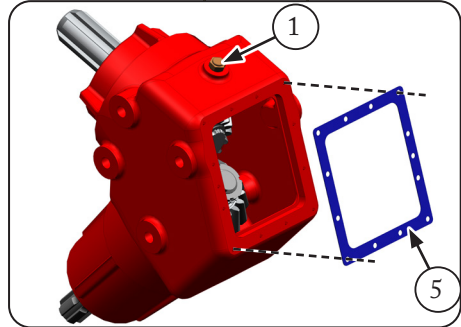
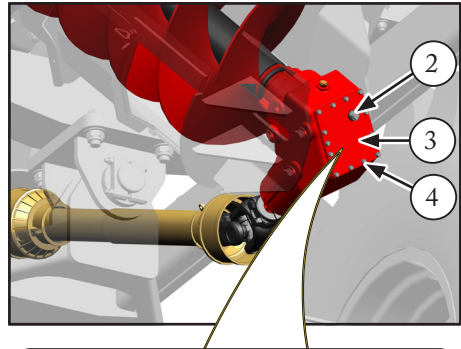

### Rotation selection gearbox:

- With the Tanker level, place a collection container under the gearbox.
- Remove plugs (1 and 6) and drain the oil from the gearbox.
- Reinstall plug (6).
- Refill the gearbox with the recommended oil, until it reaches the level sight glass (2).
- Reinstall plug (1).

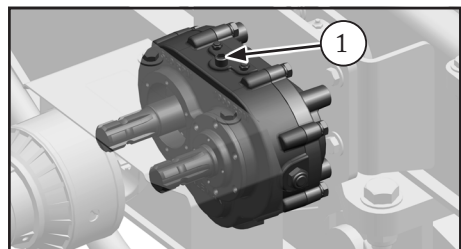
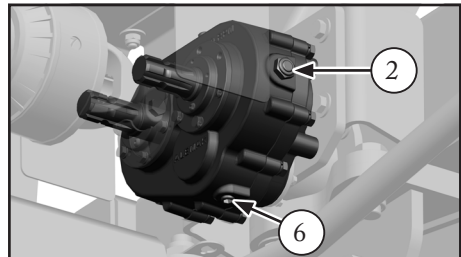

### 7.4 - Tire inflation

Proper tire inflation has a significant impact on their service life.

Check tire pressure with the tires cold.

If necessary, inflate them.

The recommended pressure for each type of tire is shown in the table below, expressed in pounds per square inch (psi).

*NOTE: For the recommended tires for each Tanker, see item 3.10.*

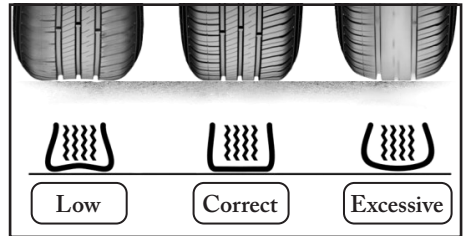

Tire	Recommended pressure (pounds per square inch)
18.4-34 TM 95 (12 ply)	32
23.1-26 MB 39 (14 ply)	24
24.5-32 TM 95 (12 ply)	24
28.1-26 MB 39 (14 ply)	24
30.5-32 MB 39 (14 ply)	22

### 7.5 - Electromagnetic clutch adjustment (If equipped)

With the use of the clutch the clearance increases due to wear of the armature and rotor.

When the clearance is outside the specified range (4 a 7 mm), the clutch will take longer to engage the auger. At this time it will be necessary to adjust the clearance.

1. Support bolts.
2. Housing closing bolts.
3. Housing: formed by the half-housings (3a and 3b).
4. Splined shafts: input and output.
5. Magnetic field coil.
6. Rotor.
7. Armature assembly.
8. Adjusting bolts
9. Lock nuts.
10. Bearings.

#### Preliminary disassembly procedures.

- a) Attach the housing (3) in a vice, in the vertical position, by the motion output shaft (side where the electrical cable is located).
- b) Loosen the bolts (1 and 2), open the assembly, separating it into two halves.
- c) internally clean clutch assembly (3).
- d) Remove armature assembly (7).

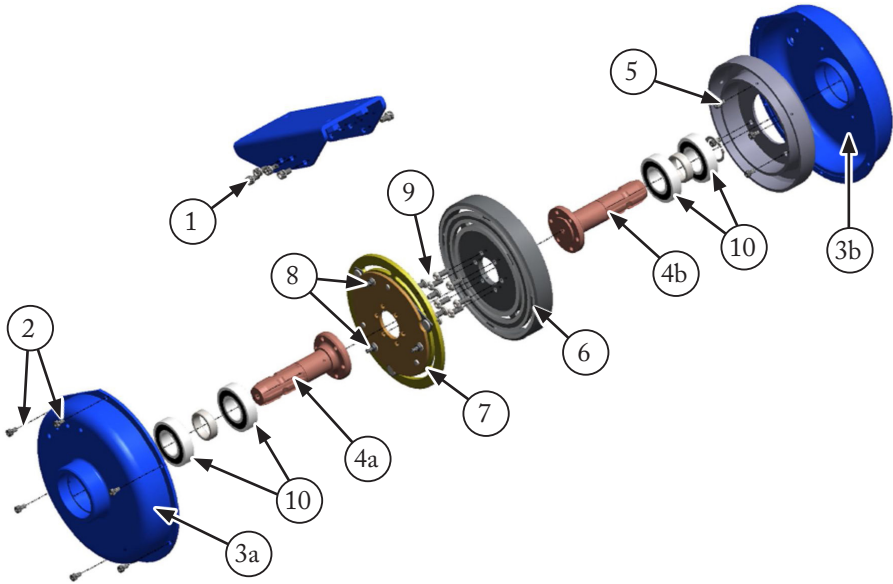

### Procedure for adjusting clearance

Remove the armature assembly (7) to access the clearance adjustment screws.

- Loosen locking nuts (9) by releasing adjusting bolts (8).
- Turn by tightening the adjusting screws for two or three turns, which will result in a 2 to 3 mm advance.
- Mount armature assembly (7) on shaft (4) and fit other housing (3).



#### **IMPORTANT:**

*The assembly will not close as the armature (7) slopes on the face of the rotor (6).*

- Measure the distance between the two clutch housings and note on a paper this measurement (clearance X). This measurement + 0.5 mm ( $X + 0.5$  mm) is the distance that should return the advance that was given in the armature (7) in item b).

Example: If the clearance between the two housings is 1.5 mm, it will be necessary to return 2 mm in the advance given in item b).

- Remove armature assembly (7) from notched shaft (4) again.
- Return armature (7) as per item c).
- The clearance adjustment screws are threaded with a pitch of 1 mm. This means that each turn of the screw corresponds to 1 mm of advance.
- After this procedure the clearance between the armature (7) and the rotor (6) will be 0.5 mm.
- Mount armature assembly (7) on shaft (4), lock bolts (9) with low torque Loctite glue.

Close again the assembly in reverse order to disassembly.

## 7.6 - Toe-In adjustment

Toe-in is as the wheels are more “closed” at the front (measured D) in relation to the rear (measured T).

Therefore, toe-in is the difference between these measurements (D and T) =  $T - D$  (in mm).

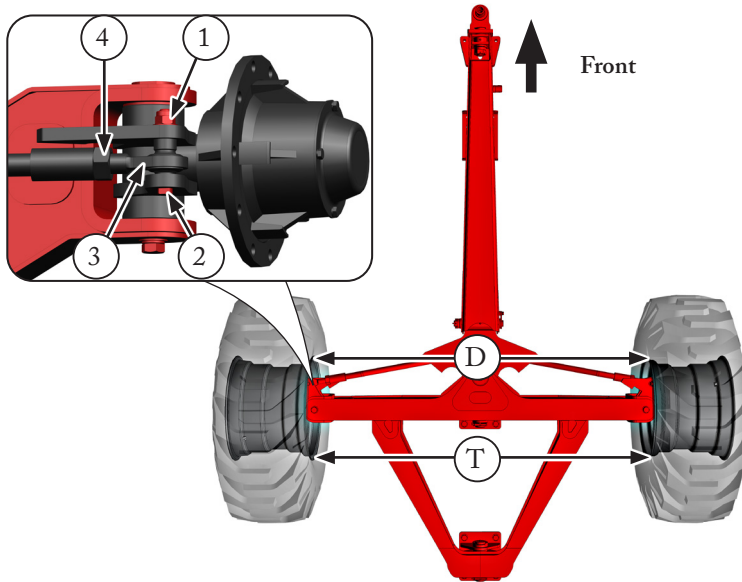

### How to measure toe-in

- Keep the header centered, that is, with the wheels aligned with the center line of the machine.
- With a jumper wire, measure the front (D) and rear (T) distance. The measurement should be made between the rim of the rims at the height of the axles.
- Loosen the locknut (4) and turn the end (3) as needed.
- Reconnect the end (3) and check whether the toe-in is correct.

If necessary, disconnect the end (3) and turn it a few more turns.

*NOTE: If the toe-in is too far out of specification, make the adjustment evenly, on the steering bar on both sides of the axle.*

Toe-in ( $T - D$ ) must be 5 to 10 mm.

### To adjust:

- Disconnect the tie rod end (3) from the steering arm, removing the nut (1) and bolt (2).
- Once the correct adjustment has been obtained, reconnect the tie rod end with the bolt (2) and nut (1).
- Tighten the nut (1) and the locknut (4).

## 7.7 - Wheel hub maintenance

The wheel hub must be disassembled, the parts washed in kerosene or diesel oil, the parts inspected, reassembled, the bearing preload adjusted, and lubricated.

Some front hub parts differ in shape from the rear hubs. However, the procedure for both is identical:

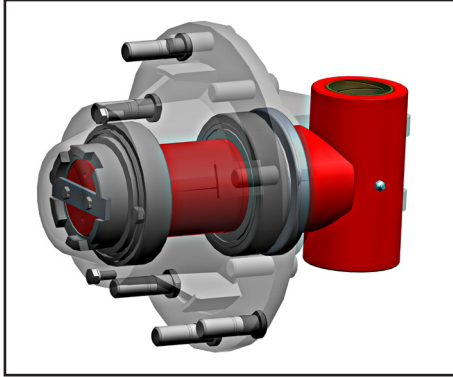

Front hubs

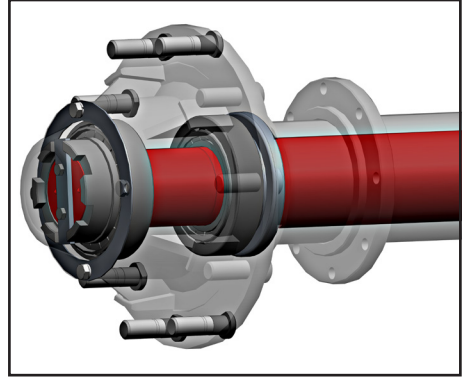

Rear hubs

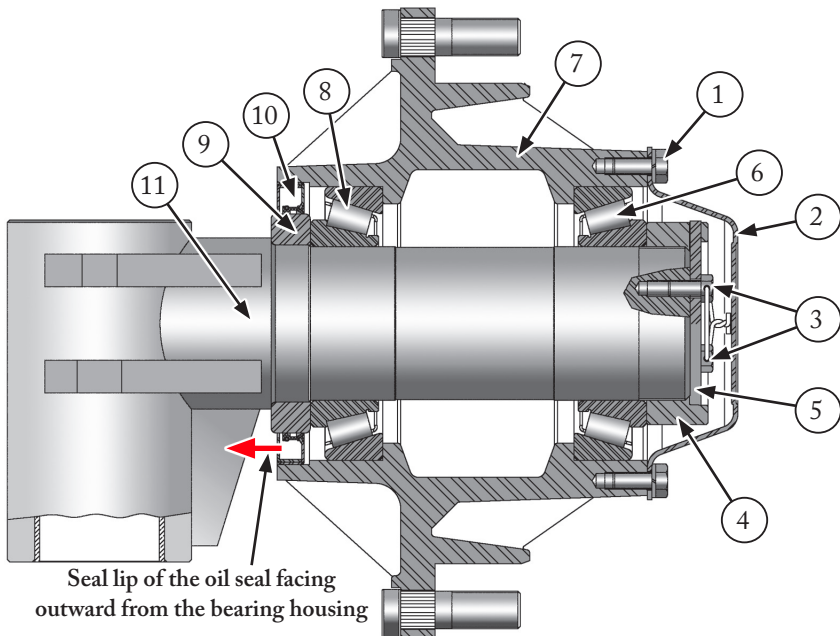

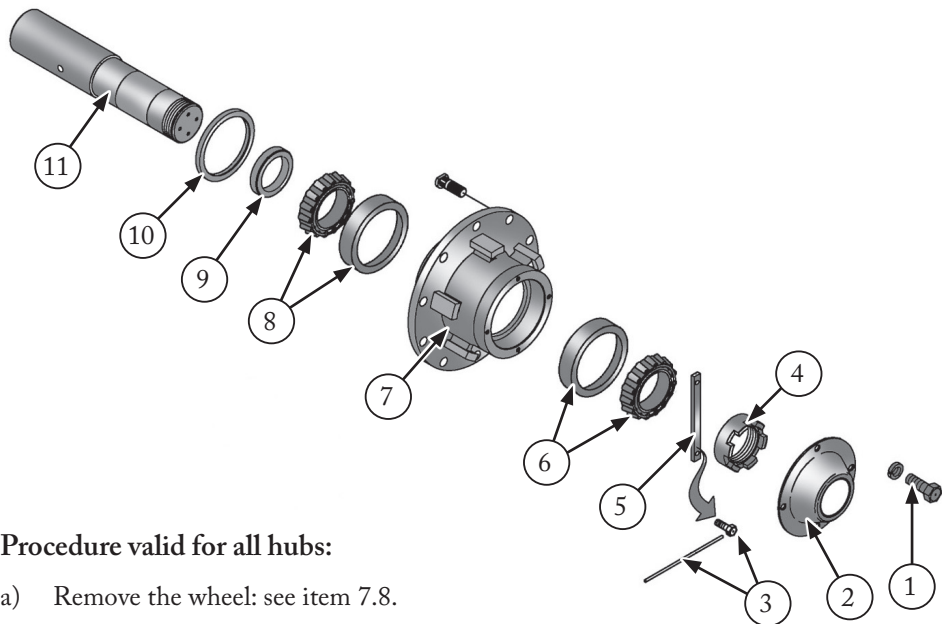
**Procedure valid for all hubs:**

- a) Remove the wheel: see item 7.8.
- b) Remove the cover (2) by removing the screws (1).
- c) Remove the lock (5) by removing the bolts and the cotter pin (3).
- d) Remove castle nut (4).
- e) Remove hub (7), bearings (6 and 8) and the other components. To do so, pull the hub.
- f) Wipe the parts using a brush and kerosene.
- g) Inspect the components, replacing whatever is necessary.  
Pay special attention to the retainer (10). If necessary, remove it destructively and assemble a new one.  
  
Also check the condition of the ring (9), on which the seal (10) runs: if necessary, also replace the ring.
- h) Lubricate all parts with the types of grease recommended on item 7.2;
- i) Install the hub following the reverse order.
- j) Adjust the bearing preload (6 and 8): when installing the castellated nut (4), tighten it until the hub offers slight resistance to rotation.
- k) Install the lock (5) and the bolts (3): secure them with wire.
- l) Proceed in the same way with the remaining hubs of the other wheels.

**IMPORTANT:**

*When installing the seal (10), observe the correct side: the sealing lip must face outward from the bearing (see figure on the previous page).*



## 7.8 - Wheel removal and installation



### **ATTENTION!**

*The Tanker axles must not be lifted simultaneously!*

*Do not perform any activity with the Tanker supported only by the jack! Position jack stands (2) with the required load capacity under the axles, in the positions indicated in the figure below:*

- Perform this procedure with the Tanker on a flat and level surface.
  - Ensure the Tanker is completely immobilized, using one of the following methods:
    - Keep it hitched to the tractor (shut off and with the parking brake applied).
    - Or place wooden chocks under the wheels that remain on the ground.
- a) Loosen the nuts (4) of the wheel(s) (3) to be removed.
  - b) Lift the axle with the jack (1), until the wheel(s) (3) are clear of the ground.
  - c) Support the axle with jack stands (2).  
*NOTE: To remove only one of the wheels, lift and support only the side of the axle corresponding to the wheel to be removed.*
  - d) Remove the nuts (4) and the wheel(s).
  - e) After reinstalling the wheel(s), raise the axle, remove the jack stands (2), lower the wheels to the ground, and apply the final tightening to the nuts (4).
  - f) To remove and install the wheels on the opposite axle, perform the same procedure above.



Image for reference only

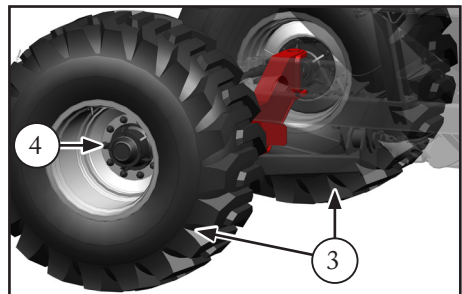
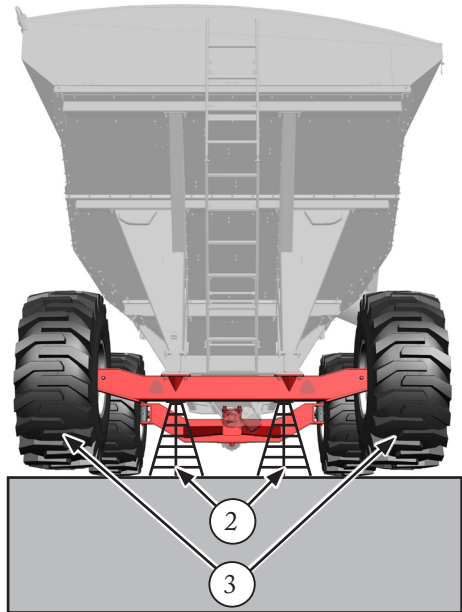

## 7.9 - Tanker cleaning and maintenance

Proper maintenance of agricultural equipment operating with corrosive chemical products depends primarily on frequent cleaning, periodic inspection, and correct storage.

Neglecting these practices may result in accelerated corrosion, reduced service life, increased maintenance costs, and operational safety risks.

### A) Machine maintenance guidelines

- Perform immediate cleaning of the equipment after completing operations, especially when there has been contact with:
  - Chloride-, Nitrogen-, Phosphorus-, and Potassium-based fertilizers (NPK) - see figure alongside.
  - Chemically treated seeds.
  - Micronutrients, inoculants, or chemical conditioners.
- Use plenty of clean water, completely removing residues, deposits, and accumulated dust.
- Avoid using aggressive cleaning products, acids, or strong alkalis, especially on stainless steel components.



Image for reference only

### Special attention to stainless steel



**NOTE:**

*Tankers in the stainless steel version have a decal (shown beside) providing information on care for preserving stainless steel.*

**ATENÇÃO  
ATTENTION  
ATENCIÓN**

**CUIDADOS NA CONSERVAÇÃO E MANUTENÇÃO DO AÇO INOXIDÁVEL**  
 O aço inox possui excelente resistência à corrosão, decorrente da formação de um fino filme de óxidos e hidróxidos à base de cromo (Cr) regenerativo sobre a superfície e, portanto, exige cuidados para manter suas propriedades inalteradas.  
 Faz-se necessário a manutenção, limpeza manual, mecânica ou química com objetivo de eliminar a adesão de contaminantes, incrustações na superfície do inox preservando a sua integridade.  
 A vida útil do aço inox pode sofrer alterações devido a concentrações, composições com presença de cloratos, sais, soluções de pH ácido, umidade, temperatura do meio e estado de conservação do inox.  
 Consulte manual de instrução para maiores informações.

**CARE IN THE CONSERVATION AND MAINTENANCE OF STAINLESS STEEL**  
 Stainless steel has excellent resistance to corrosion, resulting from the formation of a thin film of regenerative chromium (Cr)-based oxides and hydroxides on the surface and, therefore, requires care to keep its properties unchanged.  
 Maintenance, manual, mechanical or chemical cleaning is necessary in order to eliminate the adhesion of contaminants and scale on the stainless steel surface, preserving its integrity.  
 The useful life of stainless steel may change due to concentrations, compositions with the presence of chlorides, salts, acidic pH solutions, humidity, temperature of the environment and the state of conservation of the stainless steel.  
 See instruction manual for more information.

**CUIDADO EN LA CONSERVACIÓN Y MANTENIMIENTO DEL ACERO INOXIDABLE**  
 El acero inoxidable tiene una excelente resistencia a la corrosión, resultante de la formación de una fina película de óxidos e hidróxidos regenerativos a base de cromo (Cr) en la superficie y por lo tanto, requiere cuidado para mantener inalteradas sus propiedades.  
 Es necesario realizar mantenimiento, limpieza manual, mecánica o química para eliminar la adhesión de contaminantes e incrustaciones en la superficie del acero inoxidable, preservando su integridad.  
 La vida útil del acero inoxidable puede variar debido a concentraciones, composiciones con presencia de cloruros, sales, soluciones de pH ácidas, humedad, temperatura del ambiente y el estado de conservación del acero inoxidable.  
 Consulte el manual de instrucciones para obtener más información.

20000000026

**Code: 200000000826 - Care for the maintenance and preservation of stainless steel.**

**NOTE:**

*Follow the instructions indicated on the label to ensure proper cleaning, prevent corrosion, and maintain the service life of the components.*

- Even stainless steel components must be kept clean and free of deposits, as fertilizer and salt buildup prevent the formation of the passive chromium oxide layer, reducing corrosion resistance.
- Whenever possible, perform washing followed by drying, avoiding prolonged residual moisture.

**Protection of painted surfaces (carbon steel)**

- Regularly inspect the paint, identifying:
  - Scratches, chips, blisters, or peeling areas.
  - Areas of higher abrasion (corners, welds, edges, material flow zones).
- Keep the paint intact, as it is the primary barrier against oxidation.

**Protection of surfaces with metallic coating (galvanization)**

- Avoid "white rust" (zinc oxidation caused by retained moisture) and accelerated corrosion due to chemical fertilizers.
- Remove residues from metal surfaces by washing after use to neutralize corrosive salts:

- After washing, dry the parts completely.

Zinc requires exposure to dry air to form a stable zinc carbonate layer; retained moisture causes white oxidation.

- Apply protective products to form a film that repels water and chemical residues.
- Maintenance and preservation, if the zinc layer suffers scratches or mechanical wear:
  - Apply zinc-based protective products, in aerosol (spray), to touch up areas where the base metal (steel) has been exposed. This restores galvanic protection at the affected location.

**Proper storage**

- Store the equipment in a covered, dry, and ventilated area, preferably away from environments with fertilizer dust or corrosive atmosphere.
- Avoid storing the equipment with chemical product in the hopper, even for short periods.

**Use of protective products**

- Periodically apply specific products for stainless steel surface protection that preserve the passive layer of the material, avoiding oily products or waxes that may retain contaminants:
  - On internal parts of hoppers and metal components.
  - On stainless steel, use only compatible products that do not contaminate or attack the surface.

## B) Corrective actions

### Removal of deposits and residues

- Completely eliminate fertilizer deposits and chemical residues adhered to surfaces. On stainless steel, use:
  - Plastic bristle brushes or compatible stainless steel brushes.
  - Cleaning products specifically designed for stainless steel, when necessary.



### Treatment of corrosion points on carbon steel

- Remove oxidation by mechanical brushing, sanding, or light blasting, depending on severity.
- Apply an appropriate anticorrosive primer and repaint with compatible paint recommended for agricultural environments.



### Restoration of stainless steel surfaces

- If localized corrosion is present, clean and remove the contaminating material.
- If necessary, perform chemical passivation according to applicable standards and technical procedures.
- Replace components when corrosion compromises structural integrity or safety.

### Periodic inspections

Establish a visual and functional inspection plan, observing:

- Critical material accumulation points.
- Welds, bolted joints, and sharp edges.
- Internal areas of hoppers and ducts.



7.10 - Suggested spare parts for stock

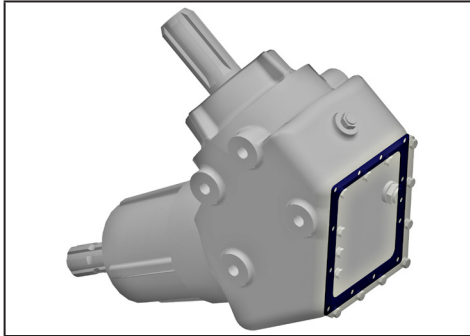

Transmission gearbox gasket.  
 Part Number: 200000001409  
 Suggested quantity: 01

Oil for the transmission gearbox and rotation  
 selection gearbox.  
 See item 7.3 - A) on recommended products.  
 Suggested quantity: 04 liters



**A) The product doesn't have enough flow rate or it is not continuous. Check whether:**

1. There are no foreign objects at the bottom of the tank, obstructing the exit.
2. The gate is fully open.
3. There is a tunnel being formed on the collection box, caused by excessive moisture of the product.

**B) Clogging and grain damage occur. Check if:**

1. No breakage of the dragging pins of the unloading tube augers occurred.
2. The unloading operation was not stopped and, afterward, excessive travel of the Tanker was carried out with the discharge tube full of product, causing compaction.

**C) There is vibration or unusual noise. Check if:**

1. The crossheads of the drive shafts present wear or excessive clearance and were lubricated regularly.
2. The driveshaft yokes are not misaligned: check the matching of the marks: see item 5.2.
3. Bolts, nuts, bearings and other components are properly fastened.
4. There are foreign objects in the inside of the tank and/or unloading tube.
5. The discharge helicoid is unbalanced.

**D) The transmission gearbox shows excessive heating. Check if:**

1. The oil level is correct and whether it has been changed within the recommended interval: see item 7.3.

**E) During transport with the Tanker loaded, lateral instability occurs. Check if:**

1. The tire inflation pressure is as recommended: see item 7.4.
2. The ground speed is compatible with the traffic conditions.
3. The load being transported is not above the recommended capacity: see specifications in item 3.6.
4. The wheels (rim and tire) are installed in the recommended position: see item 4.3.



We believe that with the information contained in this Manual, you, the user, will be able to clarify your questions regarding the Tanker 20,000, 25,000, and 30,000.

But if setbacks occur, we advise you to look for assistance at the nearest Dealer. If necessary, he will request aid from Jan's Technical Assistance, which will be available to solve problems as fast as possible.

Below, clarification on Warranty and spare parts is provided.

## Ways to contact Jan:

See the contact information on the back cover of the Manual.

## 9.1 - Spare parts

Whenever you need to replace parts on the Tanker, use Jan original spare parts only. These spare parts are properly designed for the product, within strength and adjustment conditions, and, therefore, won't harm the machine's functionality. In addition, original spare parts will ensure the client's warranty term is preserved.

When requesting these parts from your dealer, always provide the manufacturing date of your Tanker, written on the serial number plate (1).

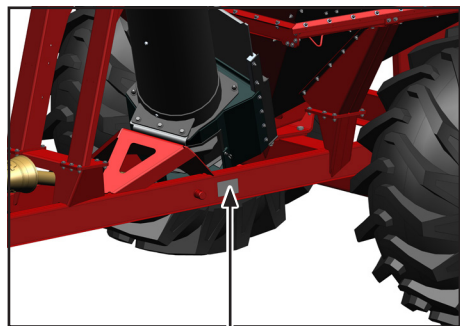

Model 20,000 with  
one axle

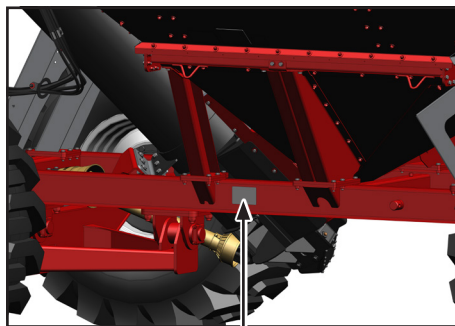

Models 20,000, 25,000  
and 30,000 with two  
axles



### 9.2 - Jan Warranty Terms

The Warranty term, expressed herein, is the Dealers' responsibility towards their Clients. It shouldn't, therefore, be used as an understanding instrument between the Client and Manufacturer.

The conditions below are basic and will be considered whenever a dealer submits to Jan's discretion a Warranty request.

1. Jan warrants this product only to the first purchaser for a period no longer than 6 (six) months, counted from the day of the delivery.
2. This Warranty covers exclusively workmanship and material defects, being labor, freight and other expenses not covered by this Certificate, as they are the dealer's responsibility.
3. Any attachments which have not been exclusively manufactured by us will not be covered by this Warranty term and their warranty claims should be sent to their respective dealers or manufacturers.
4. The Warranty will be void if it's verified that the defects or damages presented result from inappropriate use of the equipment, non-compliance with the instructions or the operator's lack of experience.
5. The Warranty will be also void if the product is repaired or altered in a workshop or by mechanics that do not take part in our dealers network.
6. Parts and components that present defects derived from inappropriate application of other non-genuine parts or components will also be excluded from the Warranty term.
7. Any product that suffers any kind of inappropriate care, which may put one's safety at risk, will also be excluded from the Warranty term, according to the company's own discretion. In this case, the warranty term will be terminated definitely.
8. Workmanship and/or material defects, objects of this Warranty, will not constitute, under any circumstance, a reason for sale and purchase contract cancellation or for indemnification of any nature.



**NOTE:**

*Implementos Agrícolas Jan S.A. reserves the right to introduce changes in the designs and/or make improvements to its products without incurring any obligation to make such changes to products manufactured previously.*





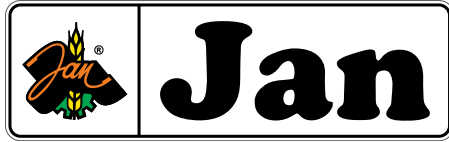

**IMPLEMENTOS AGRÍCOLAS JAN S/A**

**Management: Senador Salgado Filho Street, 101**

**Factory: Av. Dr. Waldomiro Graeff, 557 - P.O. Box 54**

**Phone: +55 54 93332-6500**

**E-mail: [decom@jan.com.br](mailto:decom@jan.com.br)**

**CNPJ: 91.495226/0001-66**

**ZIP Code: 99470-000 - Não Me Toque - RS/BRAZIL**

**Site: [www.jan.com.br](http://www.jan.com.br)**



**Code Publication: 200000004183**

**Review: 01**

**Date: 05/2026**